

420 Mobile Piston Pump  
Design Code B

ADU041  
ADU049

ADU062  
ADU080



**EATON**

*Powering Business Worldwide*

# Introduction

## 420 Series Mobile Piston Pump

Eaton's 420 Series mobile pumps are open circuit, axial piston designs with displacements of 41cc, 49cc, 62cc, and 80cc for operating speeds up to 2,650 rpm. They are available with a variety of control options to match their performance to a broad range of mobile applications.

The highly efficient pump controls reduce cooling system requirements, allowing a smaller and less expensive design to be used. Or, cooling capacity can be kept the same and the flow capability of the system increased to improve performance.

A strong, field-proven rotating group allows the pumps to handle pressures to 280 bar (4000 psi) continuous and 320 bar (4600 psi) intermittent – with less maintenance cost. 420 Series pumps use a saddle-type swashplate with steel-backed polymer bearings and a pressure lubrication passage to reduce wear and support internal loads.

The swashplate is very stiff, which reduces deflection and allows even loading of the bearings to extend the unit's service life. The combination of high load capacity bearings and a stiff drive shaft help provide a pump B10 bearing life of 3320 hours at rated mobile conditions, reducing operating costs and extending operating life.

A single control piston is used to vary pump output. This design reduces the forces acting on the swashplate, resulting in reduced package size, which allows pump installation into tighter locations.

In response to customer expectations and regulatory requirements, Eaton has designed the 420 Series pumps to operate at very low noise levels. A bimetal timing plate is used to improve pump filling characteristics which further reduces fluid-borne noise and extends pump life.

Both SAE and ISO mounting flange configurations are available as well as SAE and ISO tube- and flange-type ports. Side- or end-ported models are available to facilitate plumbing and help fit the pump to machine space needs, as are multiple drain ports to allow many mounting orientations.



### Typical Applications

- Loader backhoes
- Vibratory cable plows
- Mining machinery
- Dump truck lifts
- Agriculture tractors
- Chemical applicator trucks
- Railroad equipment
- Container handling, all-terrain, and truck cranes
- Vibratory cable plows
- Mining machinery and tunnel boring equipment
- Utility boom, off-road dump, and refuse trucks
- Material handling trucks and rough terrain fork lifts
- Concrete and asphalt pavers
- Feller/bunchers, forwarders, and log loaders
- Crawler dozers
- Articulate haulers
- Mini-excavators

### Features and Benefits

- Long pump life
- Quiet pump operation
- Low installed and operating costs
- Reduced maintenance
- Flexibility in machine design
- Compact size saves space
- Design promotes leak-free system

# Table of Contents

<b>Model Codes</b> .....	4
<b>Specifications and Performance</b> .....	6
<b>Control Options</b>	
Load Sense and Pressure Compensator .....	7
Pressure Compensator .....	8
Torque Control .....	9
Cold Start Valve .....	10
<b>Performance</b>	
ADU041 .....	11
ADU049 .....	14
ADU062 .....	17
ADU080 .....	20
<b>Pump Installation</b>	
B-mount – Rear-ported .....	23
B-mount – Side-ported .....	24
C-mount – Rear-ported .....	25
C-mount – Side-ported .....	26
Thru-Drive SAE A Option .....	27
Thru-Drive SAE B Option .....	28
Dual Shaft Seal Option .....	29
<b>Control Installation</b>	
Load Sense and Pressure Compensator .....	30
Pressure Compensator .....	31
Torque Control .....	32
Cold Start Valve .....	33
<b>External Manual Stroke Adjustment</b> .....	34
<b>Input Shaft Options</b> .....	35
<b>Center of Gravity</b> .....	38
<b>Installation and Start-up</b> .....	39

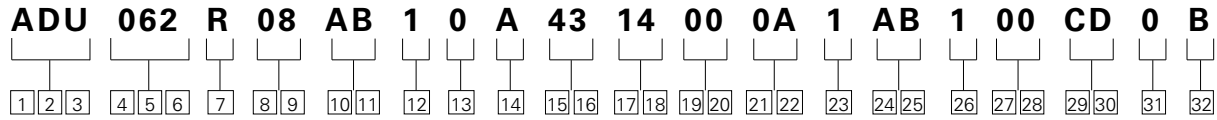

- 1 2 3 Pump Series**  
**ADU – 420 Series Open Circuit Piston Pump**
- 
- 4 5 6 Pump Displacement**  
**041 – 41.0 cm<sup>3</sup>/r [2.50 in<sup>3</sup>/r]**  
**049 – 49.2 cm<sup>3</sup>/r [3.00 in<sup>3</sup>/r]**  
**062 – 62.3 cm<sup>3</sup>/r [3.80 in<sup>3</sup>/r]**  
**080 – 80.0 cm<sup>3</sup>/r [4.88 in<sup>3</sup>/r]**
- 
- 7 Input Shaft Rotation**  
**R – Right Hand**  
**L – Left Hand**
- 
- 8 9 Front Mount and Shaft**  
**01 – 2 Bolt B, 22.2 mm (0.875in.) Dia. Keyed Shaft**  
**02 – 2 Bolt B, 25.4 mm (1.00in.) Dia. Keyed Shaft**  
**03 – 2 Bolt B, 22.22 mm (.875in.) Dia. Tapered Keyed Shaft**  
**05 – 2 Bolt B, 13 Tooth 16/32 Spline**  
**08 – 2 Bolt B, 15 Tooth 16/32 Spline**  
**32 – 2/4 Bolt C, 14 Tooth 12/24 Spline**  
**33 – 2/4 Bolt C, 31.8 mm (1.25in) Dia. Keyed Shaft**  
**34 – 2 Bolt B, 15 Tooth 16/32 Sled Runner Spline**  
**35 – 2 Bolt B, 14 Tooth 12/24 Spline**  
**38 – 2/4 Bolt C, 31.75 mm (1.25) Dia. Tapered Keyed Shaft**

- 10 11 Main Ports Size & Location**  
**AA – Rear Ports Suction - 2" (Code 61); Pressure - 1" (Code 61)**  
**AB – Side Ports Suction - 2" (Code 61); Pressure - 1" (Code 61)**  
**AC – Rear Ports Suction - 2" (Code 61) with M12 Threads; Pressure - 1" (Code 61) with M10 Threads.**  
**AD – Side Ports Suction - 2" (Code 61) with M12 Threads; Pressure - 1" (Code 61) with M10 Threads.**  
**AE – Rear Ports Suction - SAE O-Ring Port; Pressure - UN-2B SAE O-Ring Port (ADU041 & ADU049 only)**  
**AF – Side Ports Suction - #24 SAE O-Ring; Pressure - #16 SAE O-Ring (ADU041 and ADU049 Only)**  
**AG – Rear Ports Suction - M48 Metric O-Ring; Pressure - M33 Metric O-Ring (ADU041 & ADU049 Only)**  
**AH – Side Ports Suction - M48 Metric O-Ring; Pressure - M33 Metric O-Ring (ADU041 & ADU049 Only)**  
**AK – Rear Ports Suction - 2" (Code 61); Pressure - #16 SAE O-Ring (ADU062 Only)**

- 12 Case Drain Ports**  
**1 – #12 SAE O-Ring - Top**  
**2 – #12 SAE O-Ring - Bottom**  
**3 – M27 x 2 O-Ring - Top**  
**4 – M27 O-Ring - Bottom**  
**5 – #12 SAE O-Ring - Left Side (Swash Sensor Boss)**  
**6 – G 3/4 (BSPP) - Top**
- 
- 13 Diagnostic Pressure Ports**  
*Not available on thru-drive units*  
**0 – No Diagnostic Pressure Ports**  
**1 – #6 SAE O-Ring - Plugged (Rear Ports Only)**  
**2 – M14 Metric O-Ring - Plugged (Rear Ports Only)**  
**3 – #4 SAE O-Ring - Plugged (Side Ports Only)**  
**4 – M12 Metric O-Ring - Plugged (Side Ports Only)**

- 14 Controller Type**  
**A – Pressure Flow Compensator With #4 SAE O-Ring Load Sense Port**  
**B – Pressure Flow Compensator With M12 Metric O-Ring Load Sense Port**  
**C – Pressure Compensator Only**  
**E – Pressure Flow Compensator With G 1/4 (BSPP) Load Sense Port**  
**H – Pressure Flow Compensator With Torque Control #4 SAE O-Ring Load Sense Port**  
**J – Pressure Flow Compensator With Torque Control M12 Metric O-Ring Load Sense Port**  
**K – Pressure Compensator With Torque Control**
- 
- 15 16 Pressure Compensator Setting (Tolerance on Setting)\***  
**28 – 207-214 bar [3000-3100 lbf/in<sup>2</sup>]**  
**35 – 241-248 bar [3500-3600 lbf/in<sup>2</sup>]**  
**43 – 276-283 bar [4000-4100 lbf/in<sup>2</sup>]**

Items that are bold indicate preferred configuration.

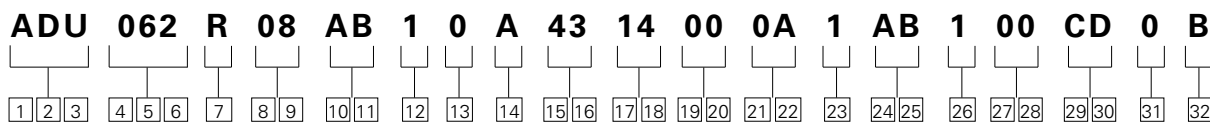

- 17 18 Flow Compensator Setting (Tolerance on Setting)\***
- 00 – No Flow Compensator Setting**
  - 14 – 12-15 bar [180-220 lbf/in<sup>2</sup>]**
  - 24 – 23-26 bar [330-370 lbf/in<sup>2</sup>]**

- 19 20 Torque Control Setting**
- 00 – No Torque Control**
  - AA – 40 Nm [350 in-lbs] (41,49)**
  - AB – 51 Nm [450 in-lbs] (41,49)**
  - AC – 62 Nm [550 in-lbs] (41,49,62)**
  - AD – 73 Nm [650 in-lbs] (41,49,62,80)**
  - AE – 85 Nm [750 in-lbs] (41,49,62,80)**
  - AF – 96 Nm [850 in-lbs] (41,49,62,80)**
  - AG – 107 Nm [950 in-lbs] (41,49,62,80)**
  - AH – 119 Nm [1050 in-lbs] (49,62,80)**
  - AJ – 130 Nm [1150 in-lbs] (49,62,80)**

- AK – 141 Nm [1250 in-lbs] (49,62,80)**
- AL – 153 Nm [1350 in-lbs] (62,80)**
- AM – 164 Nm [1450 in-lbs] (62,80)**
- AN – 175 Nm [1550 in-lbs] (62,80)**
- AP – 186 Nm [1650 in-lbs] (62,80)**
- AR – 198 Nm [1750 in-lbs] (62,80)**
- AT – 209 Nm [1850 in-lbs] (62,80)**
- AU – 220 Nm [1950 in-lbs] (80)**

- 21 22 Control Special Features**
- 00 – Control Special Features**
  - 0A – Bleed Down Orifice**
  - 0D – 12V Cold Start Valve**

- 23 Maximum Displacement Option\***
- 1 – Standard Displacement (As Given In Code Title)**
  - 2 – External Manual Stroke Adjustment**

- 24 25 Auxiliary (Rear) Mount & Output Shaft**
- 00 – No Auxiliary Mounting Features**
  - AB – SAE A 2 Bolt, 11T 16/32 Spline**
  - AC – SAE B 2 Bolt, 13T 16/32 Spline**
  - AD – SAE B 2 Bolt, 15T 16/32 Spline**
  - AE – SAE A 2 Bolt, 9T 16/32 Spline**

- 26 Shaft Seal**
- 0 – No Shaft Seal**
  - 1 – Standard Polyacrylate Shaft Seal**
  - 2 – Viton Shaft Seal**
  - 3<sup>†</sup> – Double, Two-Way Shaft Seal, Viton With VHO Filter**
  - 4 – Nitrile Shaft Seal**
  - 5 – Single Viton Shaft Seal in 2/4 Bolt C Mount Pump Housing**

<sup>†</sup> Not available on SAE B mount

- 27 28 Pump Special Features**
- 00 – No Special Features**
  - AA – Auxiliary Mounting Cover Plate**
  - AB – Swash Position Sensor**
  - AC – Shaft Speed Sensor**
  - AD – Modified End Cover, Corner Removed**
  - AE – Support Studs (1/2-13 UNC-2B x 117.8 (4.64) Long in Top Two End Cover/Housing Bolt Locations**
  - AG – Swash Position Sensor and Shaft Speed Sensor**

- 29 30 Paint**
- 00 – No Paint**
  - CD – Blue Primer**

- 31 Identification/Packaging**
- 0 – Standard Eaton Identification Box Packaging**

- 32 Design Level**
- B – Second Design**

Items that are bold indicate preferred configuration.

# Specifications and Performance

## General Performance Specifications

		Units	ADU041	ADU049	ADU062	ADU080
<b>Displacement</b>		<b>cc/r (in<sup>3</sup>/r)</b>	41.0 (2.50)	49.2 (3.00)	62.3 (3.80)	80.0 (4.88)
<b>Weight</b>	Single Seal <sup>1</sup>	<b>kg (lbm)</b>	22.9 (50.4)	22.9 (50.4)	23.8 (52.4)	24.2 (53.4)
	Dual Seal <sup>1</sup>		24.1 (53.1)	24.1 (53.1)	25.0 (55.1)	25.4 (56.1)
<b>Pressure</b>	Continuous	<b>bar (psi)</b>	280 (4060)	280 (4060)	280 (4060)	210 (3050)
	Intermittent <sup>2</sup>		320 (4600)	320 (4600)	320 (4600)	230 (3335)
	Peak <sup>3</sup>		350 (5000)	350 (5000)	350 (5000)	250 (3625)
<b>Speed<sup>4</sup></b>	At 1 bar abs (0 psig)	<b>rpm</b>	2650	2650	2600	2200
	At .85 bar abs (5 in.Hg)		2450	2450	2400	1800
	At 2 bar abs (15 psig)		2950	2950	2800	N/A
	Max (standby)		3600	3600	3600	3600
	Min		600	600	600	600
<b>Power</b>	Max (theoretical)	<b>kW (hp)</b>	50.7 (68.0)	60.8 (81.5)	75.6 (101.3)	61.7 (82.7)
	Standby		.98 (1.3)	.98 (1.3)	1.1 (1.5)	1.4 (1.9)
<b>Torque</b>	Max (theoretical)	<b>Nm (lb-ft)</b>	183 (135)	219 (162)	278 (205)	268 (198)
<b>Bearing Life<sup>5</sup></b>	At 140 bar (2030 psi)	<b>B10 Hours</b>	103,650	55,580	33,500	17,150
	At 210 bar (3045 psi)		26,830	14,380	8,670	4,440
	At 280 bar (4060 psi)		10,280	5,510	3,320	N/A
<b>Mass Moment of Inertia</b>		<b>Nm-sec<sup>2</sup></b>	.0033	.0033	.0046	.0058
		<b>(lb-in-sec<sup>2</sup>)</b>	(.0288)	(.0288)	(.0403)	(.0517)

1 Standard SAE B non-through drive.

2 Less than 10% of duty cycle.

3 Momentary system pressure spikes only.

4 Ratings based on Flange ports. Note: Tube ports are not available on the 62cc and 80cc displacements.

5 Bearing life ratings at rated speed - 1 bar abs (0 psig) inlet.

## Inlet Pressure, Case Pressure, and Operating Temperature Requirements

Inlet Pressure			Case Pressure			Operating Temperature		
Rated bar abs (psig)	Minimum bar abs (in. Hg)	Maximum bar abs (psig)	Maximum Continuous bar abs (psig)	Maximum Intermittent bar abs (psig)	Peak bar abs (psig)	Rated °C (°F)	Minimum Temperature °C (°F)	Maximum Intermittent °C (°F)
1.0 (0)	0.85 (5)	4.4 (50)	1.3 (5)	3.1 (30)	6.2 (75)	93 (200)	-37 (-35)	104 (220)

## Hydraulic Fluids

Fluid	Recommended Operating Viscosity Range cSt (SUS)	Maximum Continuous cSt (SUS)	Maximum Viscosity at Startup cSt (SUS)	Minimum Viscosity @ Max. Intermittent Temperature of 93°C (200°F) cSt (SUS)	Minimum Intermittent cSt (SUS)
Use antiwear hydraulic oil, or automotive type crankcase oil (designations SC, SD, SE or SF) per SAE J183 FEB80	16 to 40 (80 to 188)	430 (1192)	2100 (9720)	10 (59)	6 (46)

For more information, see Eaton publication 579. For operation on other alternative or environmentally friendly fluids, please contact your Eaton Representative.

# Control Options

## Load Sense and Pressure Compensator

### Load Sense and Pressure Compensator Control

The pump will provide power matching of pump output to system load demand, maximizing efficiency and improving load metering characteristics of any directional control valve installed between the pump and the load.

Load sensing ensures that the pump always provides only the amount of flow needed by the load. At the same time, the pump operating pressure adjusts to the actual load pressure plus a pressure differential required for the control action. When the system is not demanding power, the load sense control will operate in an energy-saving stand-by mode.

Typically, the differential pressure is that between the pressure inlet and service port of a proportionally controlled directional valve, or a load sensing directional control valve. See the model code on page 4 for differential pressure settings for load sensing.

If the load pressure exceeds the system pressure setting, the pressure compensator de-strokes the pump. The load sensing line must be as short as possible and can also be used for remote control or unloading of the pump pressure. For remote control purposes, it is recommended that you contact your Eaton Representative for the correct configuration of the control.

**Warning:** The pressure compensator may be adjusted beyond the rated pressure of the pump. When adjusting the pressure limiter, install a 0-350 bar (0-5000 psi) gage in the outlet gage port and limit the pressure setting to the continuous rated pressure for the pump displacement shown on page 6.

### Pressure Limit Settings

The pressure compensator uses two springs to cover the full pressure range of the ADU pumps. The high pressure spring covers the range from 140 bar (2050 psi) to 280 bar (4060 psi). The low pressure spring is adjustable from minimum pressure through 140 bar (2050 psi).

### Flow Compensator (Load Sense) Settings

There are three springs used to cover the load sense adjustment range of this control.

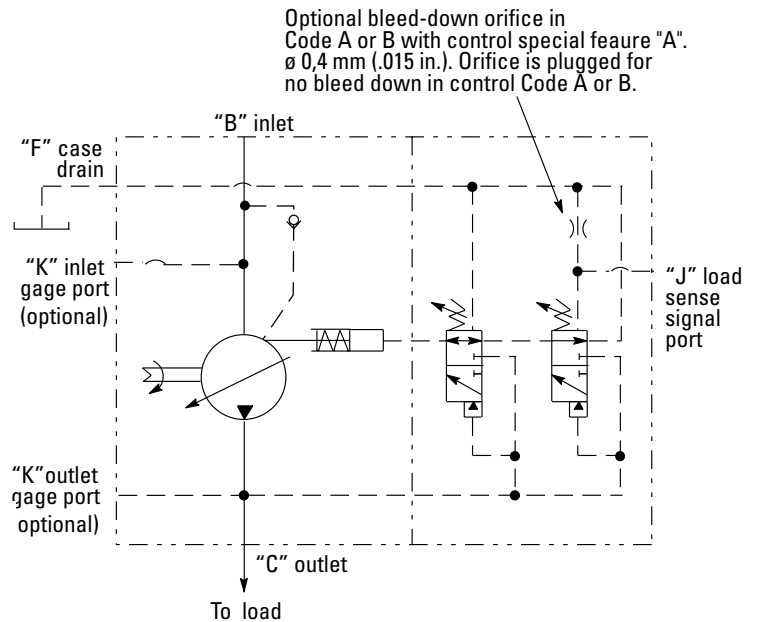

### Typical Operating Curve

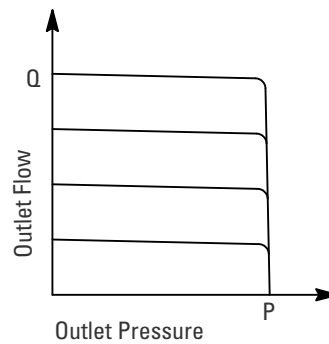

### Dynamic Response per SAE J745 (Using Swash Plate Position)

	Response (off stroke)	Recovery (on stroke)	Load Sense Recovery
	msec	msec	msec
ADU041	20	75	90
ADU049	20	75	90
ADU062	25	90	115
ADU080	26	75	115

# Control Options

## Pressure Compensator

### Pressure Compensator Control

The pump will provide a continuously modulated flow to meet changing load demands at a pre-adjusted compensator pressure. At pressures below the compensator setting, the pump will operate at maximum displacement. See model code on page 4 for compensator pressure ranges.

**Warning:** The pressure compensator may be adjusted beyond the rated pressure of the pump. When adjusting the pressure limiter, install a 0-350 bar (0-5000 psi) gage in the outlet gage port and limit the pressure setting to the continuous rated pressure for the pump displacement shown on page 6.

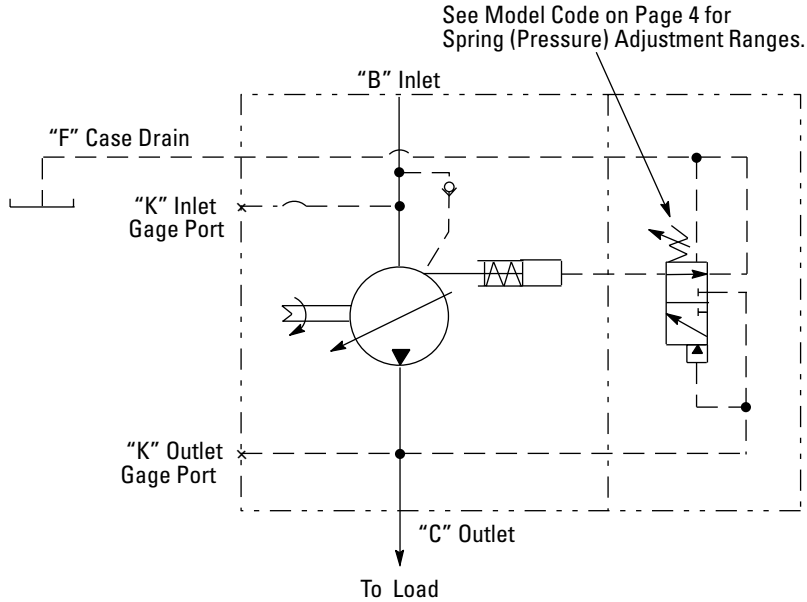

### Pressure Limit Settings

The pressure compensator uses two springs to cover the full pressure range of the ADU pumps. The high pressure spring covers the range from 140 bar (2050 psi) to 280 bar (4060 psi). The low pressure spring is adjustable from minimum pressure through 140 bar (2050 psi).

**Pressure Cut-off Characteristics of Pressure Compensator Control at 49°C (120°F), static conditions.**

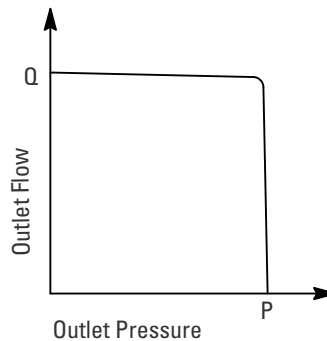

### Dynamic Response per SAE J745 (Using Swash Plate Position)

	Response (off stroke) msec	Recovery (on stroke) msec
ADU041	20	75
ADU049	20	75
ADU062	25	90
ADU080	26	75



# Control Options

## Torque Control

### Torque Control

The 420 Torque Control limits the power input to the pump preventing the engine from stalling while also optimizing the use of the engine power.

When combined with Pressure Compensator Control and/or Load Sense (refer to page 7) it will allow the 420 to remain inside the power envelope of the Pressure Flow curve. When the combination of pump flow and outlet pressure moves outside the envelope, the pump displacement will automatically be reduced.

This maximum setting is easily calculated using the following steps:

1. Select the 420 pump displacement you intend to use
2. Identify the available engine horsepower (HP) and speed (rpm)
3. Calculate the torque limit required by the system using the equations shown
4. Select the MAX torque setting from the table shown

$$\text{Torque (in-lbs)} = \frac{\text{Horsepower (HP)} \times 63025}{\text{Engine RPM}}$$

$$\text{Torque (Nm)} = \frac{\text{Horsepower (KW)} \times 9550}{\text{Engine RPM}}$$

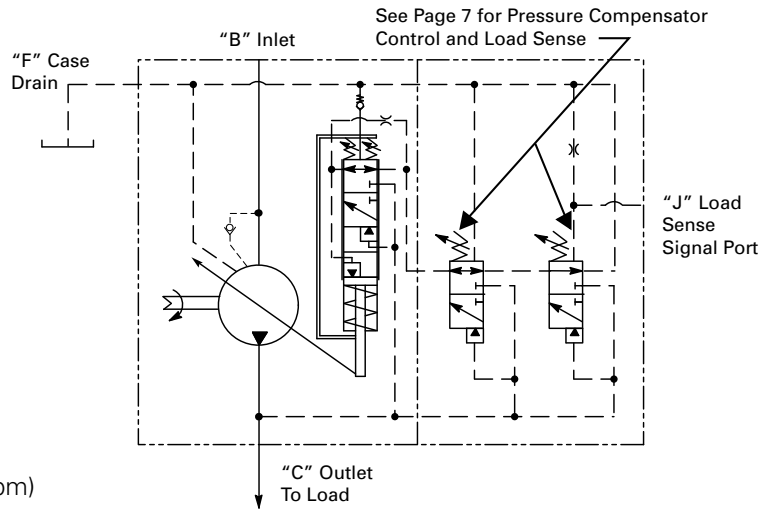

Code	Torque Setting	41CC	49CC	62CC	80CC
AA	40 Nm (350 in-lbs)	✓	✓	—	—
AB	51 Nm (450 in-lbs)	✓	✓	—	—
AC	62 Nm (550 in-lbs)	✓	✓	✓	—
AD	73 Nm (650 in-lbs)	✓	✓	✓	✓
AE	85 Nm (750 in-lbs)	✓	✓	✓	✓
AF	96 Nm (850 in-lbs)	✓	✓	✓	✓
AG*	107 Nm (950 in-lbs)	✓	✓	✓	✓
AH	119 Nm (1050 in-lbs)	—	✓	✓	✓
AJ	130 Nm (1150 in-lbs)	—	✓	✓	✓
AK	141 Nm (1250 in-lbs)	—	✓	✓	✓
AL	153 Nm (1350 in-lbs)	—	—	✓	✓
AM	164 Nm (1450 in-lbs)	—	—	✓	✓
AN	175 Nm (1550 in-lbs)	—	—	✓	✓
AP	186 Nm (1650 in-lbs)	—	—	✓	✓
AR	198 Nm (1750 in-lbs)	—	—	✓	✓
AT*	209 Nm (1850 in-lbs)	—	—	✓	✓
AU	220 Nm (1950 in-lbs)	—	—	✓	✓

\* reference 62cc

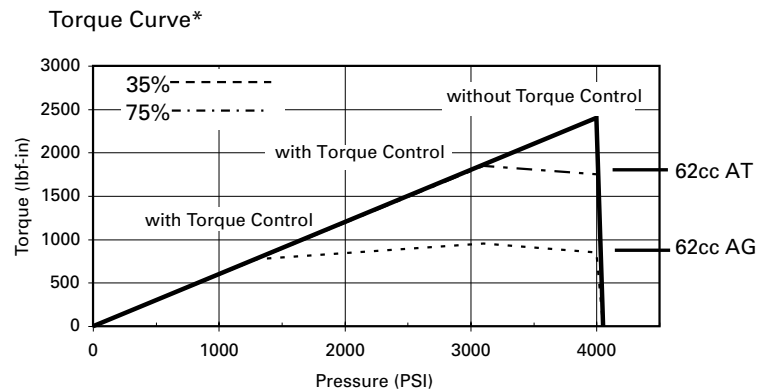
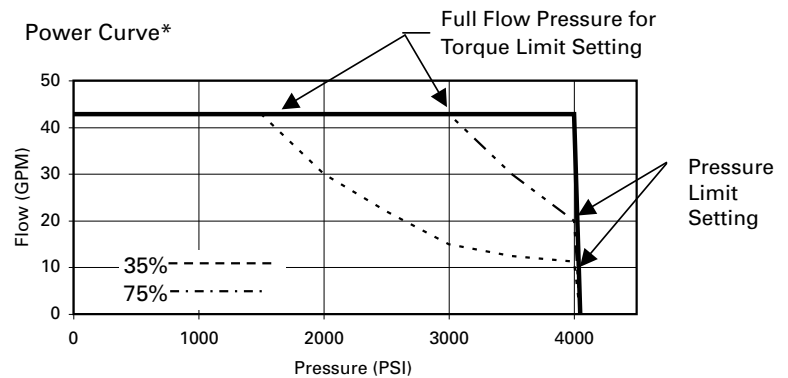

# Control Options

## Cold Start Valve

### Cold Start Valve

The 420 Cold Start Valve reduces pump start-up torque by directing control pressure to the outlet.

It is primarily used in cold weather applications and includes a 12 or 24 VDC directional control valve mounted between the pump housing and compensator.

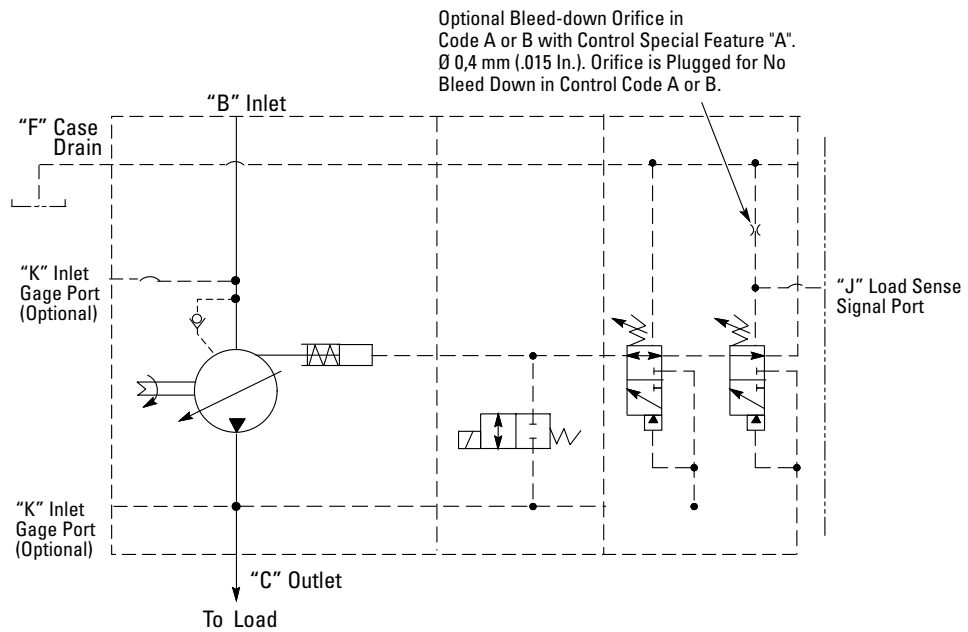

# Performance

ADU041

**Overall Efficiency Versus Speed @ 49° C (120° F), Full Flow, and 1.0 bar (0 psi) Inlet**

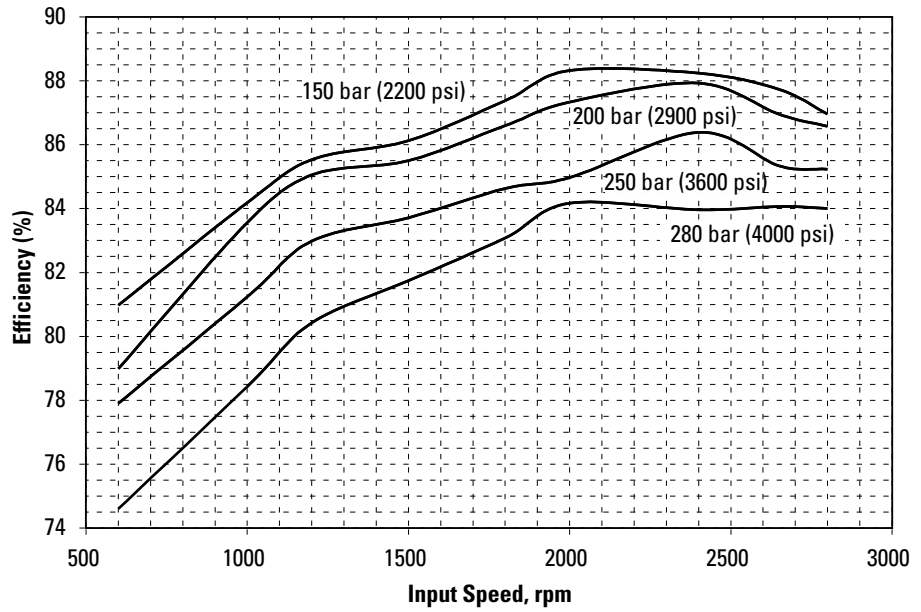

**Overall Efficiency Versus Speed @ 49° C (120° F), Full Flow, and 1.0 bar (0 psi) Inlet**

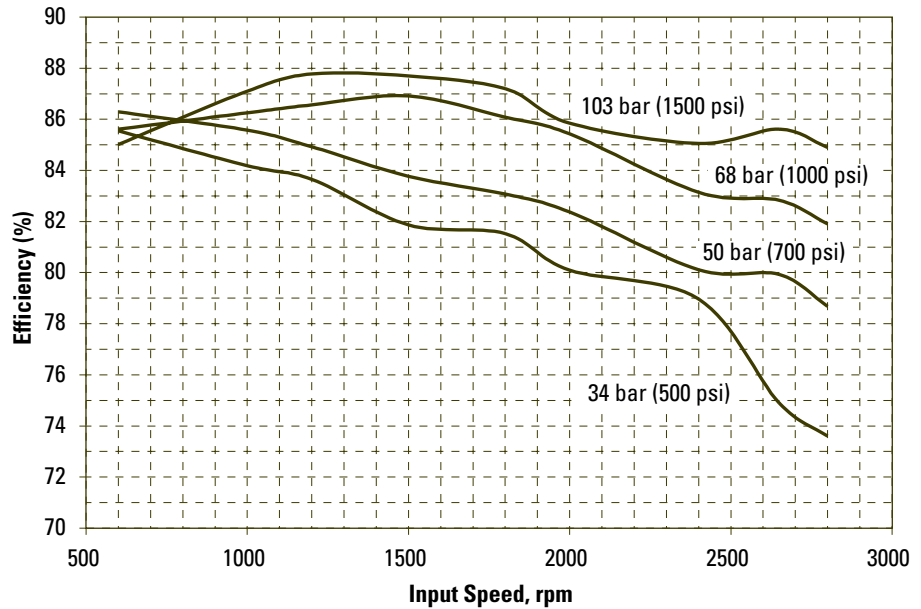

# Performance

ADU041

**Input Power Versus Speed**  
 @ 49° C (120° F), Full Flow,  
 and 1.0 bar (0 psi) Inlet

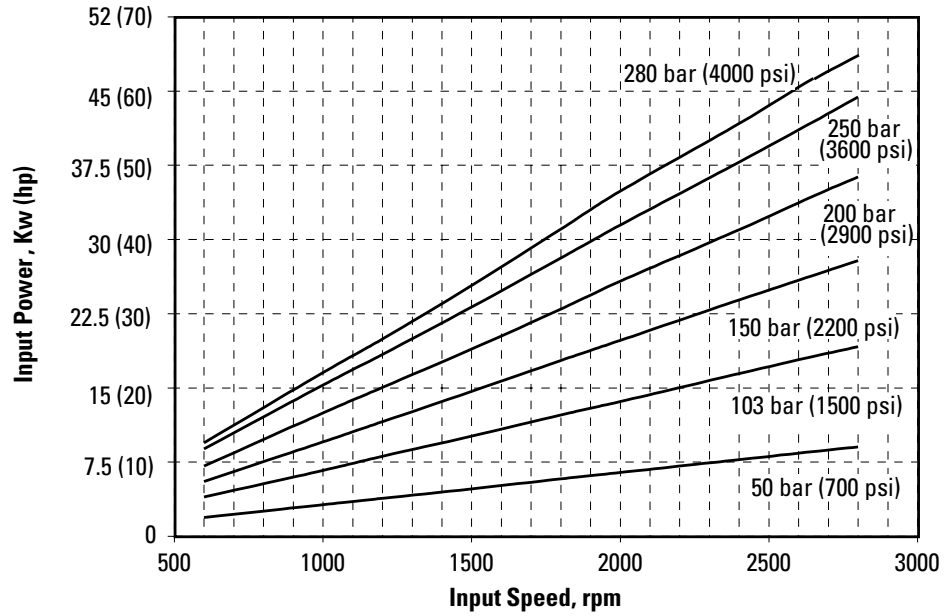

**Input Torque Versus Speed**  
 @ 49° C (120° F), Full Flow,  
 and 1.0 bar (0 psi) Inlet

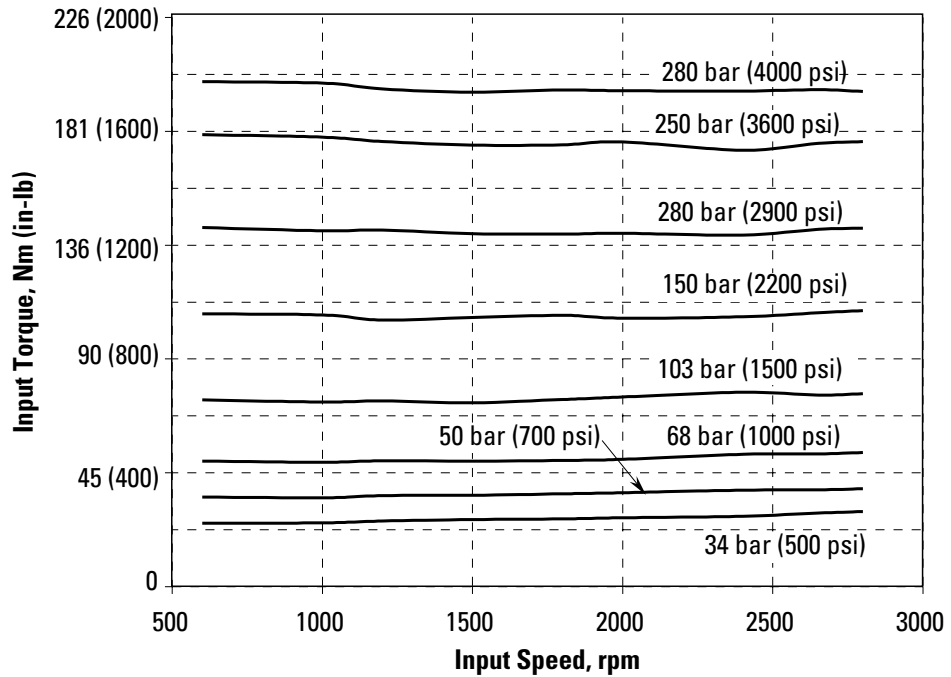

**Delivery and Case Flow Versus Speed @ 49° C (120° F)**

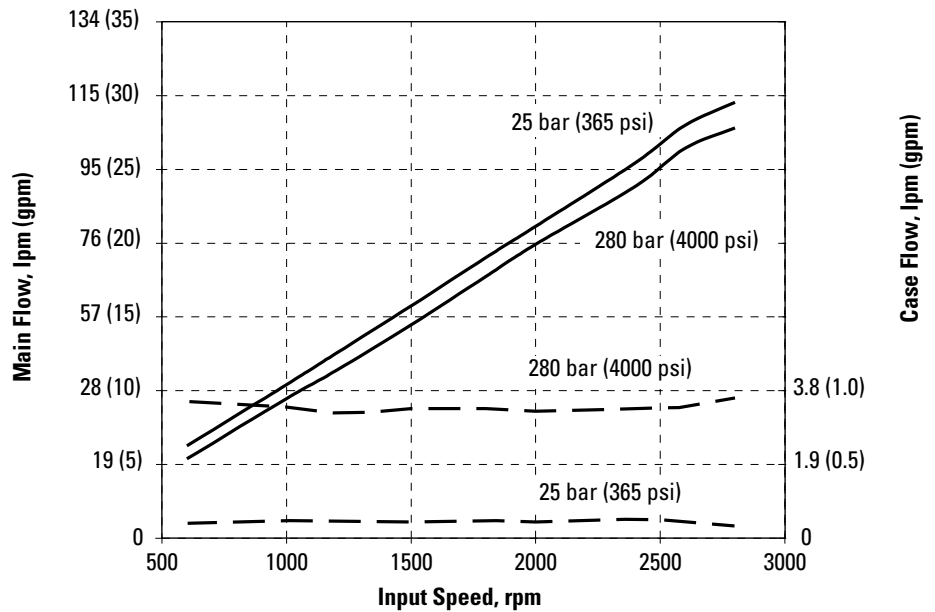

**Input Torque and Case Flow Stand-by @ 49° C (120° F)**

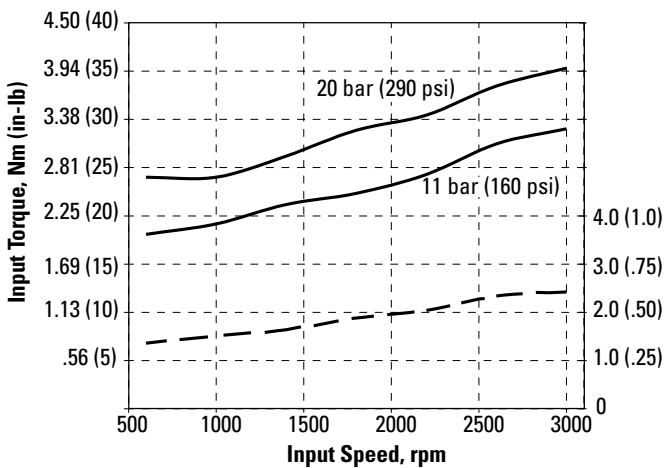

**Input Torque and Case Flow Cut-off @ 49° C (120° F)**

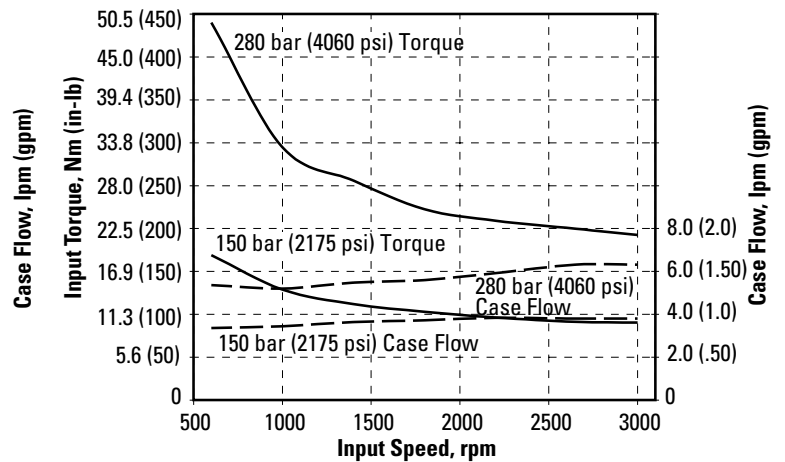

# Performance

ADU049

**Overall Efficiency Versus Speed @ 49° C (120° F), Full Flow, and 1.0 bar (0 psi) Inlet**

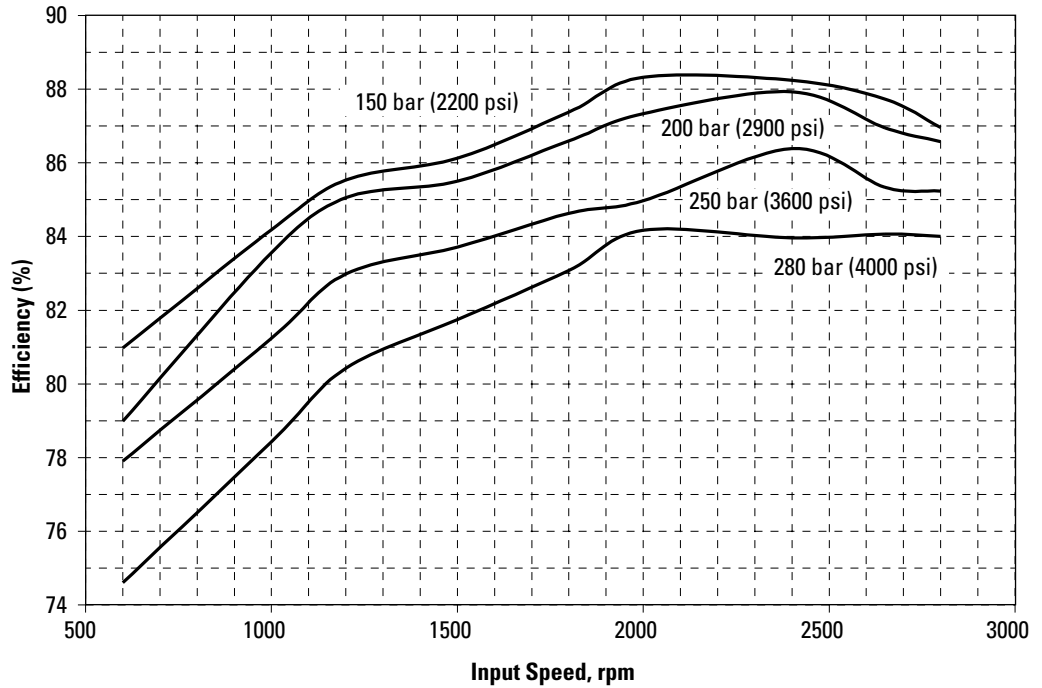

**Overall Efficiency Versus Speed @ 49° C (120° F), Full Flow, and 1.0 bar (0 psi) Inlet**

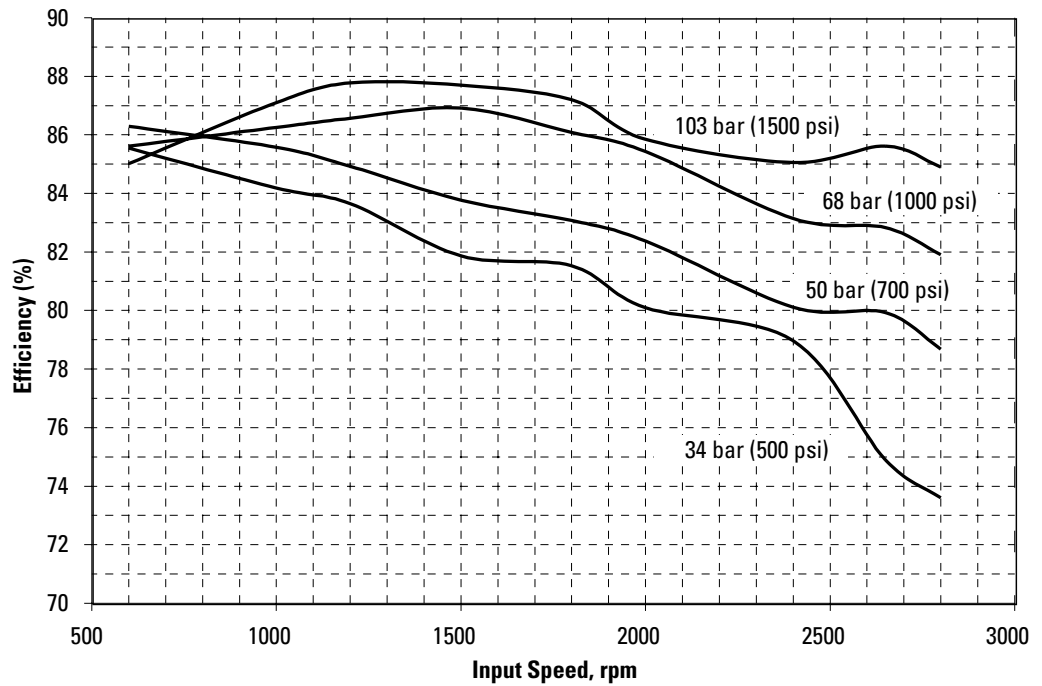

**Input Power Versus Speed**  
 @ 49° C (120° F), Full Flow,  
 and 1.0 bar (0 psi) Inlet

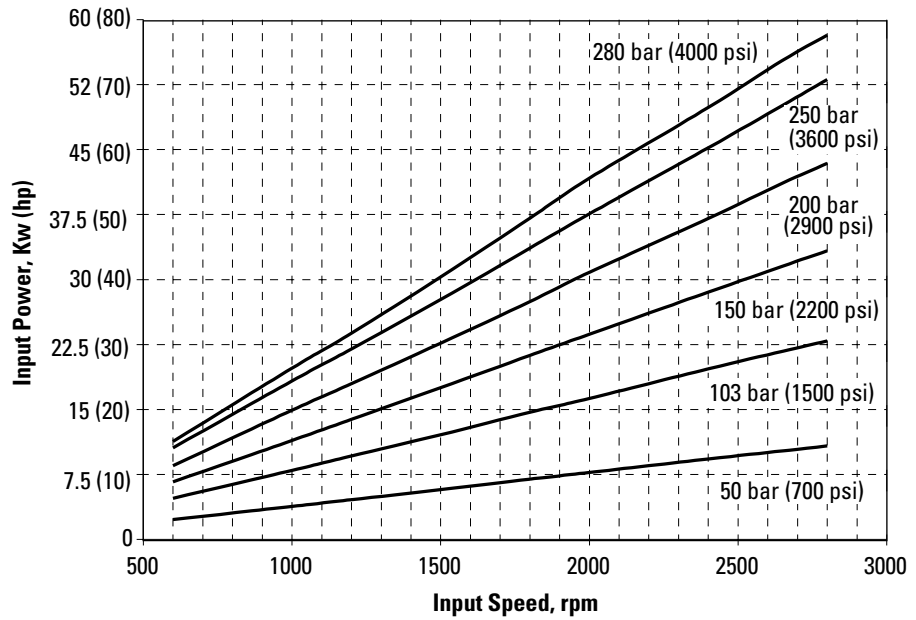

**Input Torque Versus Speed**  
 @ 49° C (120° F), Full Flow,  
 and 1.0 bar (0 psi) Inlet

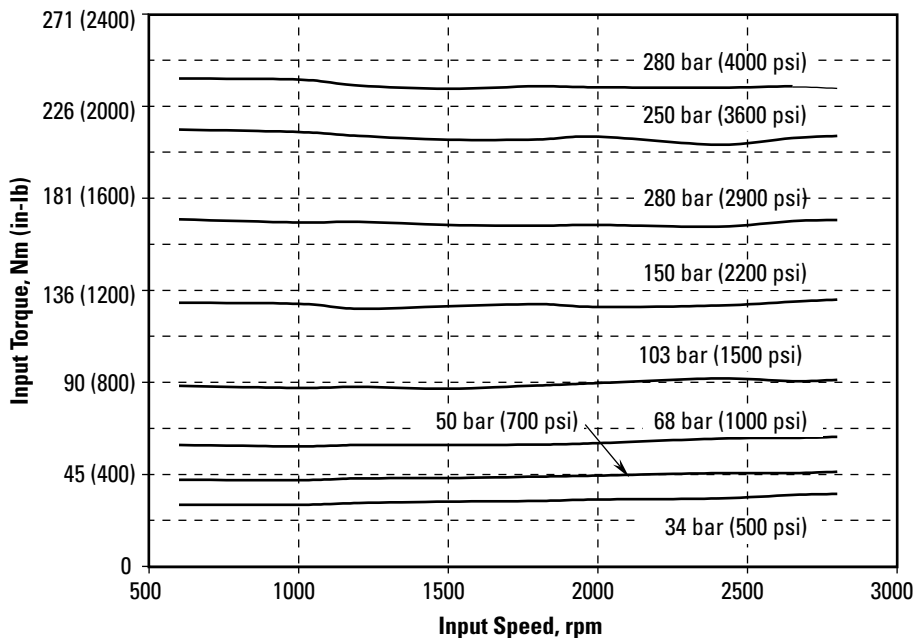

**Delivery and Case Flow Versus Speed @ 49° C (120° F)**

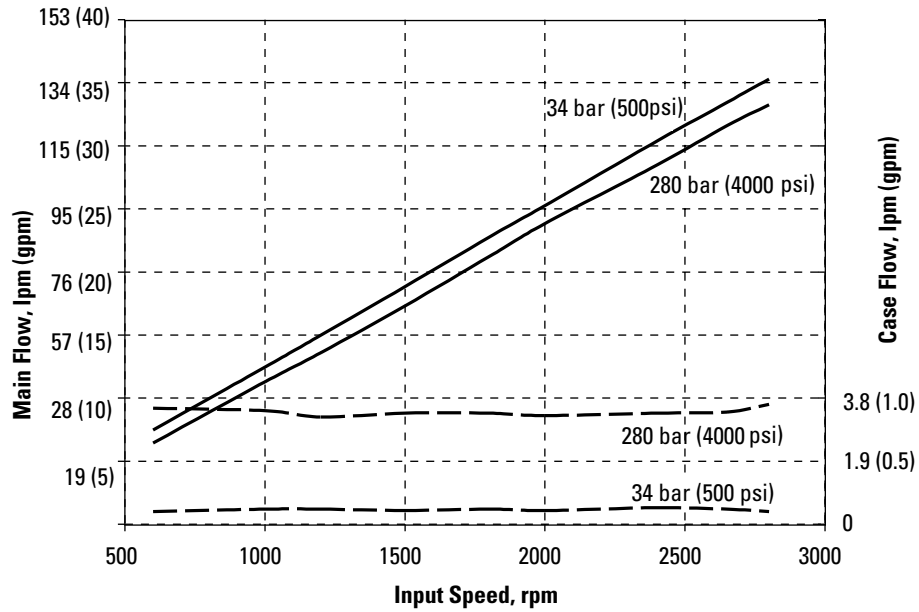

**Input Torque and Case Flow Stand-by @ 49° C (120° F)**

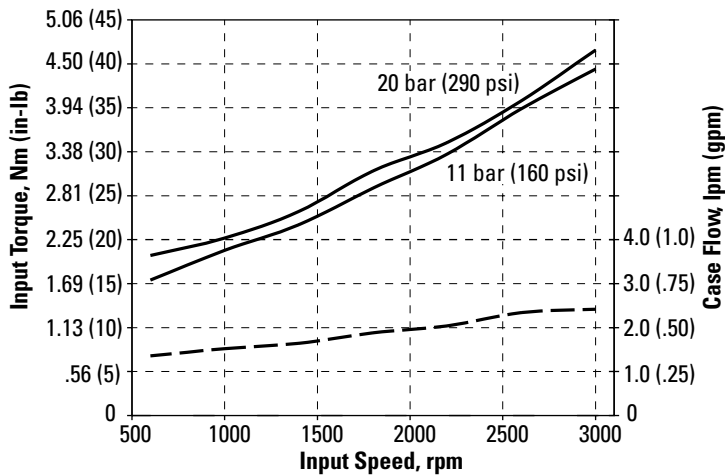

**Input Torque and Case Flow Cut-off @ 49° C (120° F)**

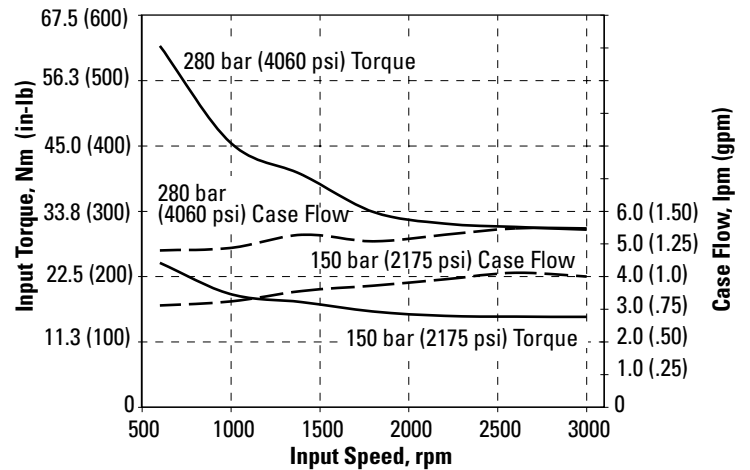



# Performance

ADU062

**Overall Efficiency Versus Speed @ 49° C (120° F), Full Flow, and 1.0 bar (0 psi) Inlet**

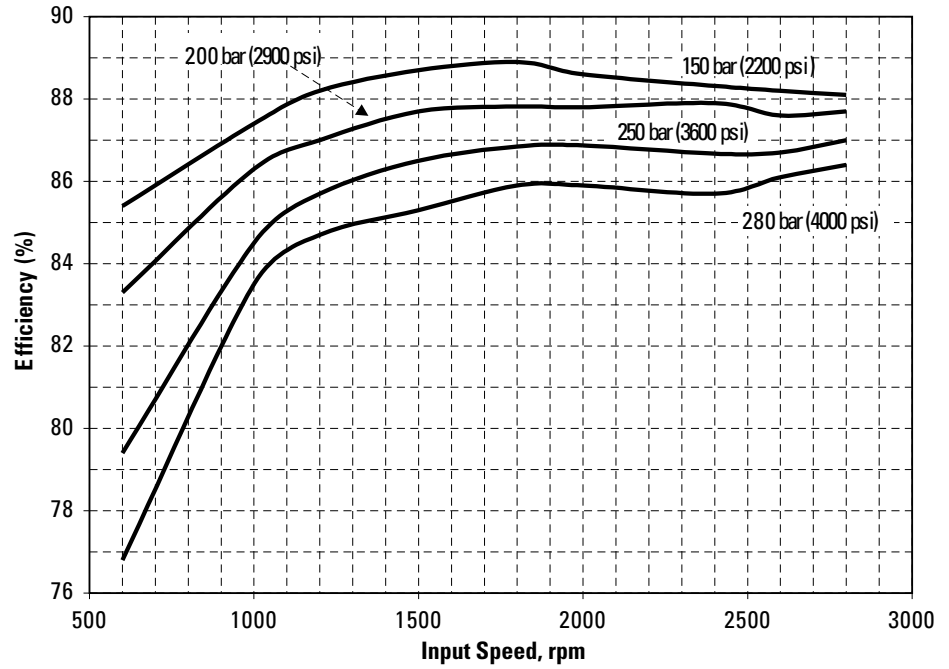

**Overall Efficiency Versus Speed @ 49° C (120° F), Full Flow, and 1.0 bar (0 psi) Inlet**

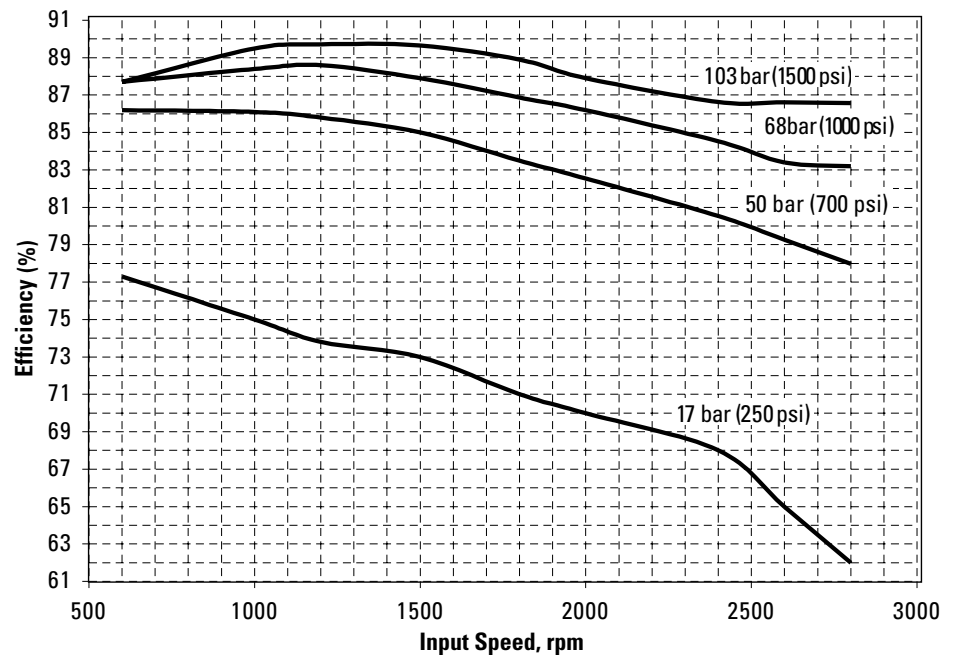

**Input Power Versus Speed**  
 @ 49° C (120° F), Full Flow,  
 and 1.0 bar (0 psi) Inlet

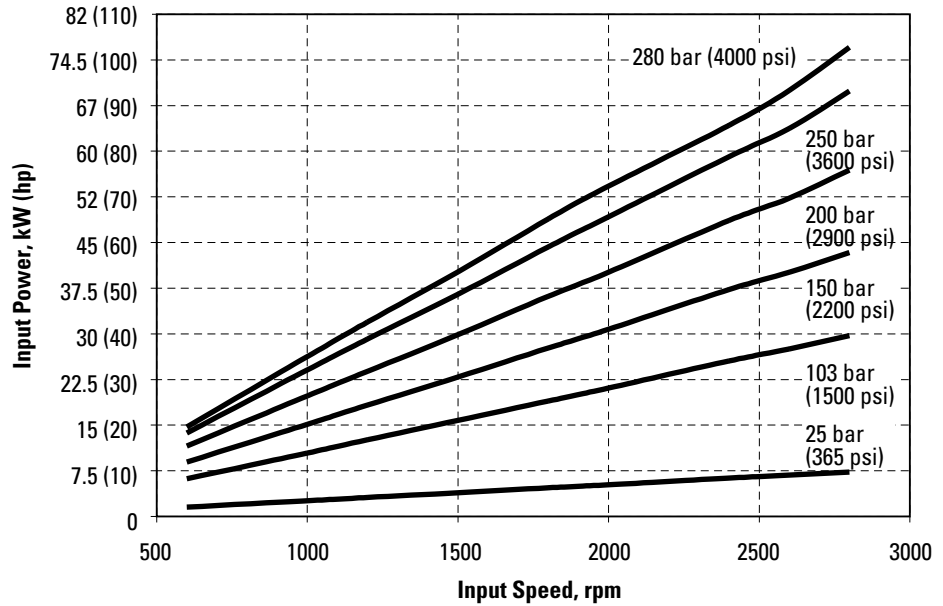

**Input Torque Versus Speed**  
 @ 49° C (120° F), Full Flow,  
 and 1.0 bar (0 psi) Inlet

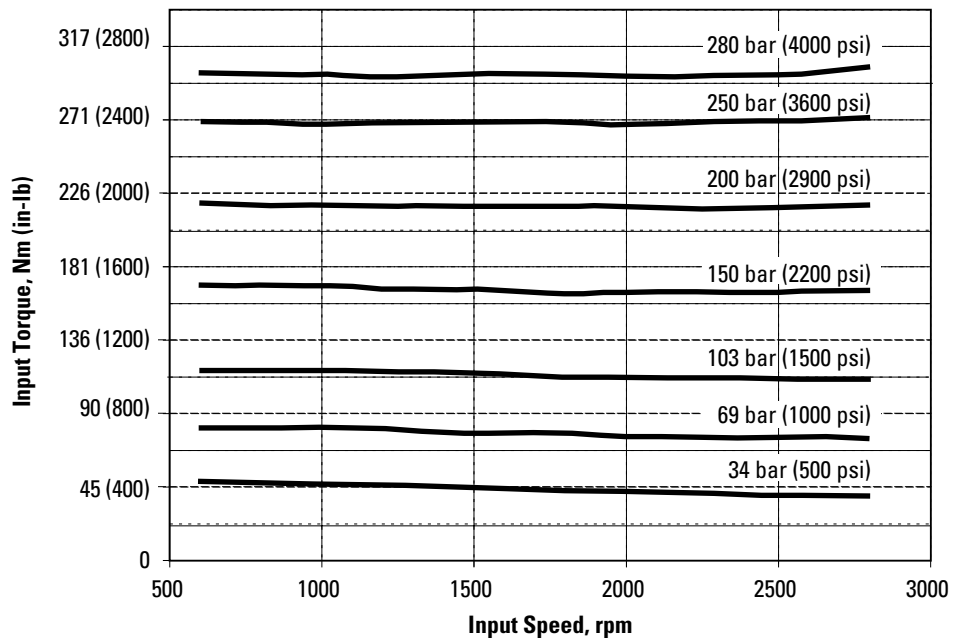

**Delivery and Case Flow Versus Speed @ 49° C (120° F)**

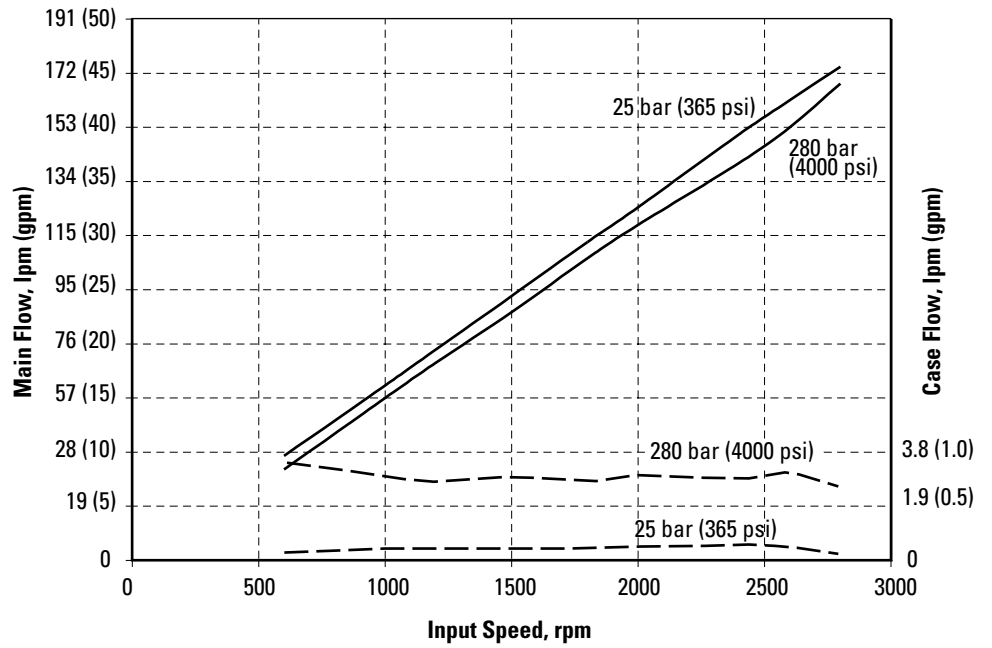

**Input Torque and Case Flow Stand-by @ 49° C (120° F)**

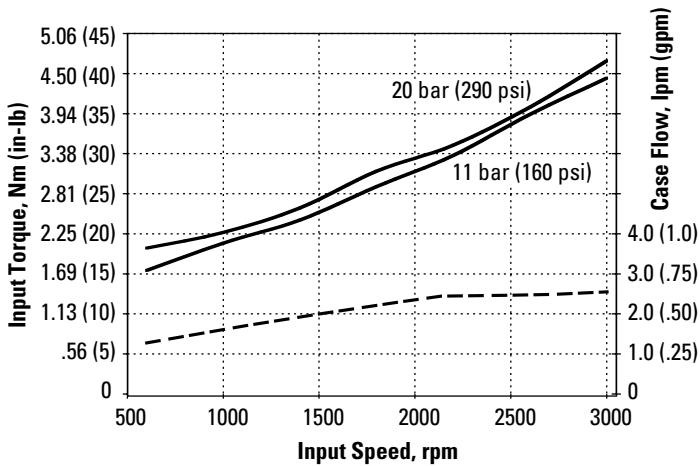

**Input Torque and Case Flow Cut-off @ 49° C (120° F)**

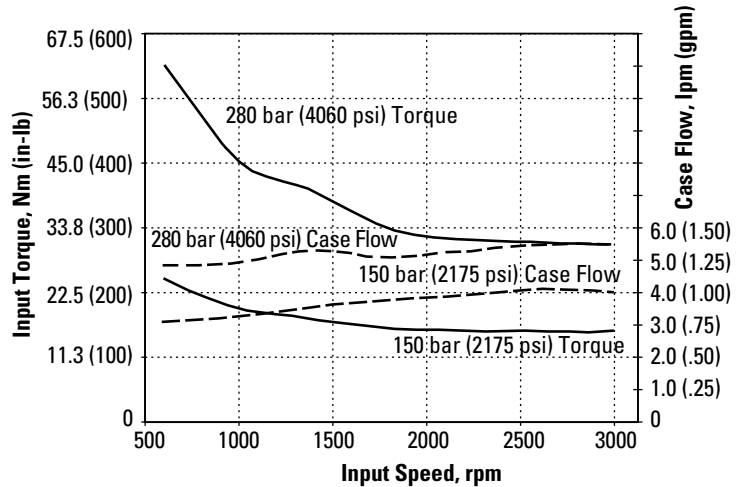

# Performance

ADU080

**Input Power Versus Speed  
@ 49° C (120° F), Full Flow,  
and 1.0 bar (0 psi) Inlet**

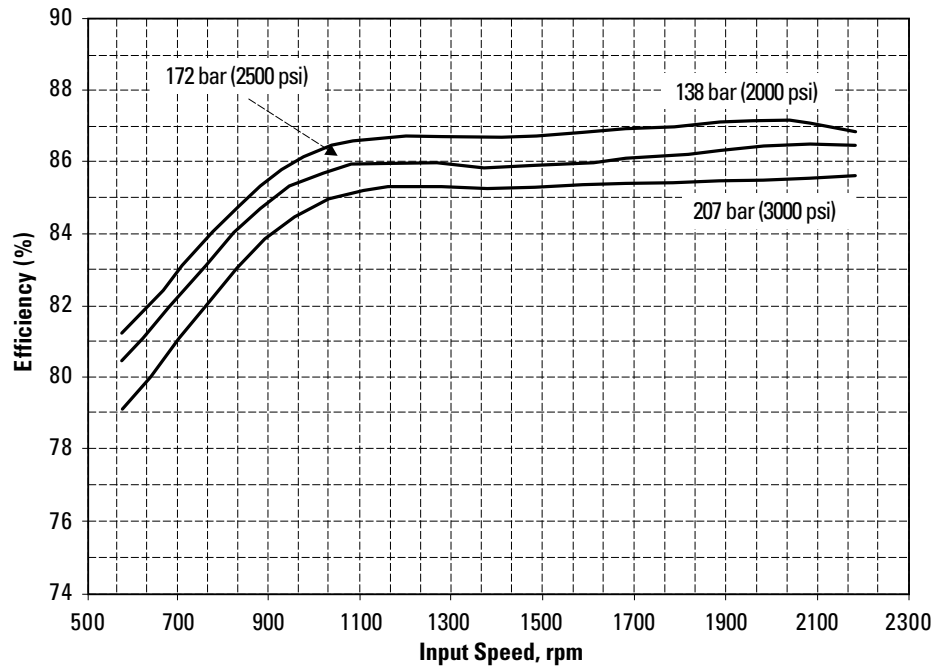

**Overall Efficiency Versus  
Speed @ 49° C (120° F),  
Full Flow, and 1.0 bar  
(0 psi) Inlet**

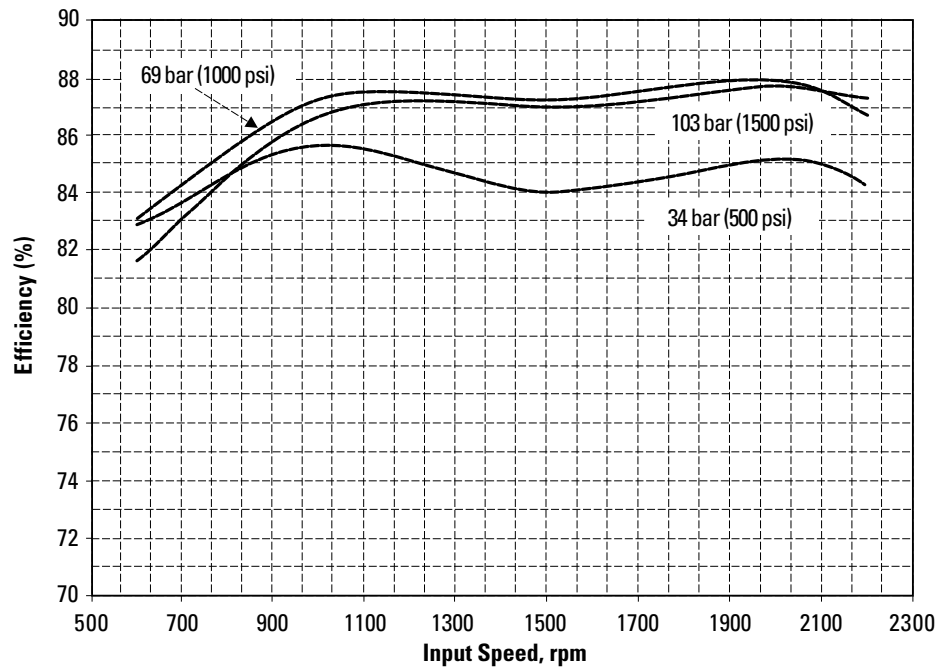

**Input Power Versus Speed**  
 @ 49° C (120° F), Full Flow,  
 and 1.0 bar (0 psi) Inlet

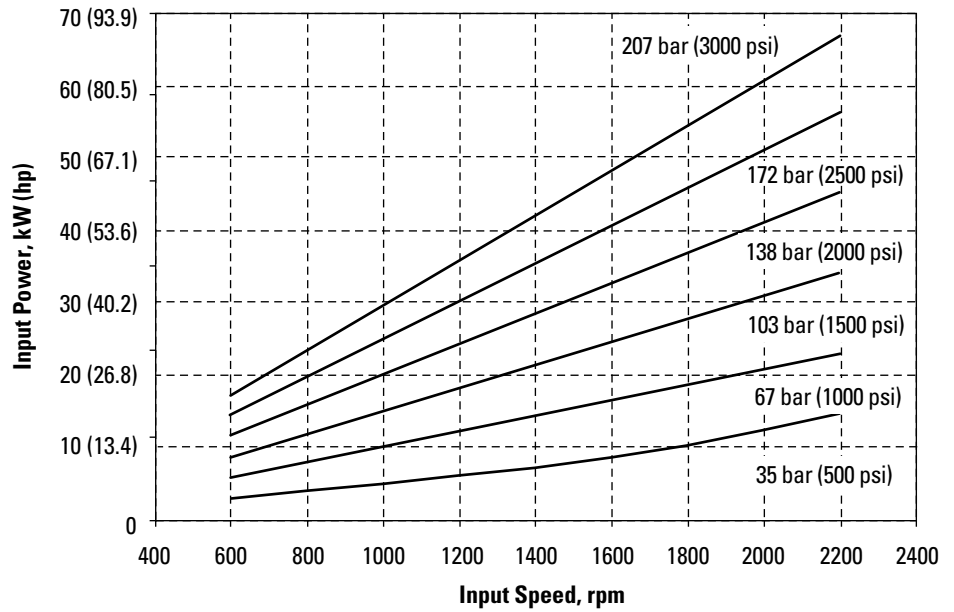

**Input Torque Versus Speed**  
 @ 49° C (120° F), Full Flow,  
 and 1.0 bar (0 psi) Inlet

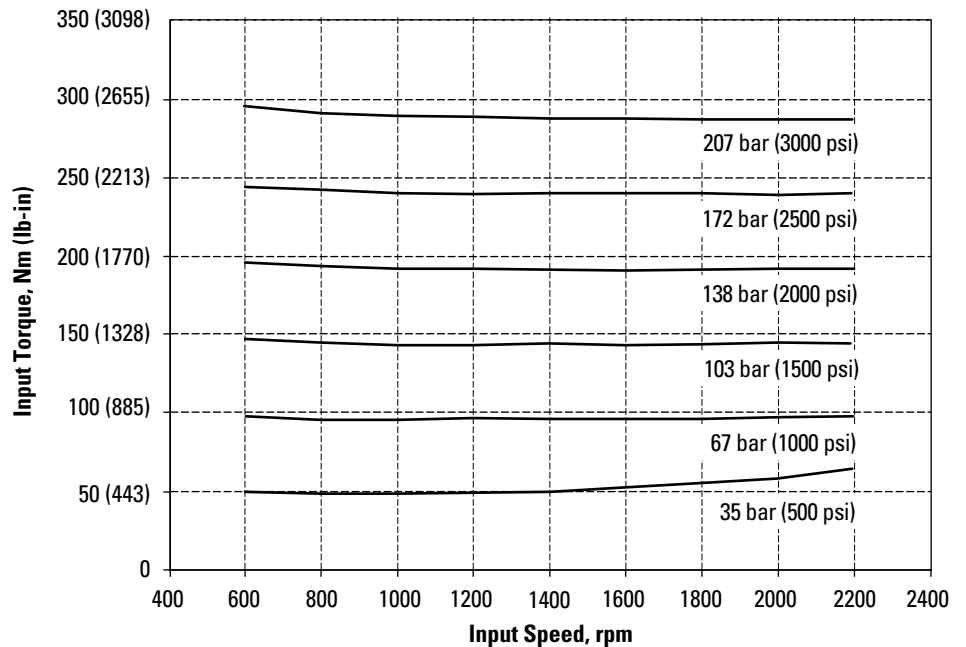

**Delivery and Case Flow Versus Speed @ 49° C (120° F)**

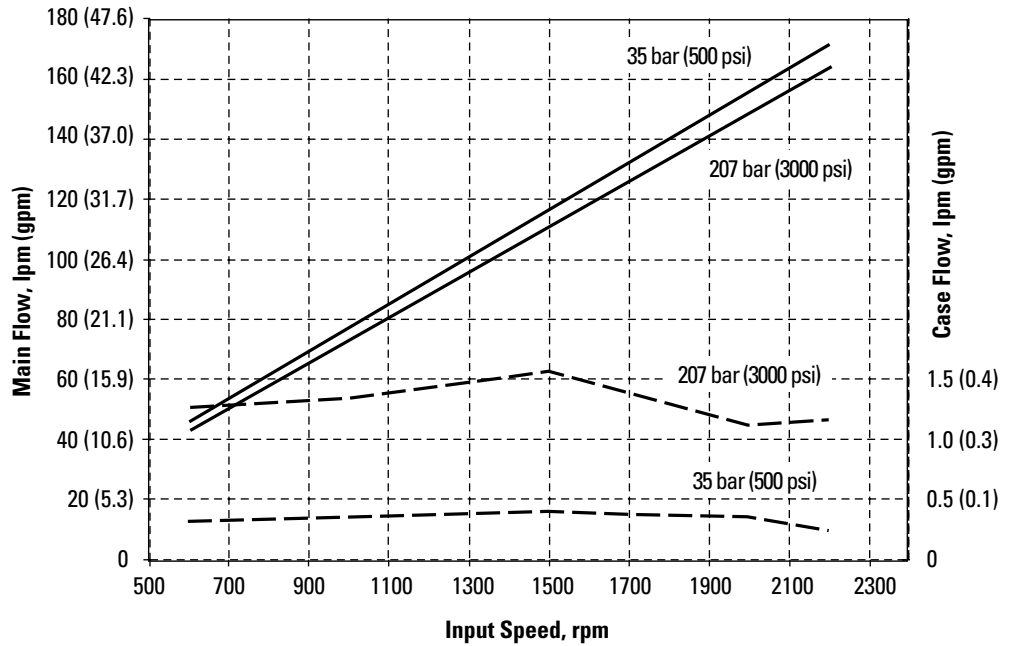

**Input Torque and Case Flow Stand-by @ 49° C (120° F)**

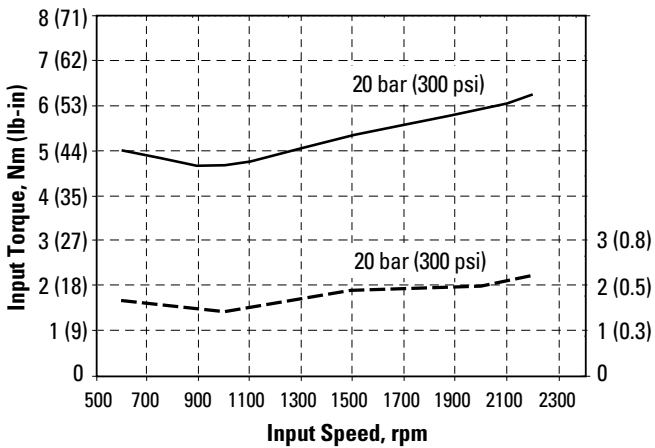

**Input Torque and Case Flow Cut-off @ 49° C (120° F)**

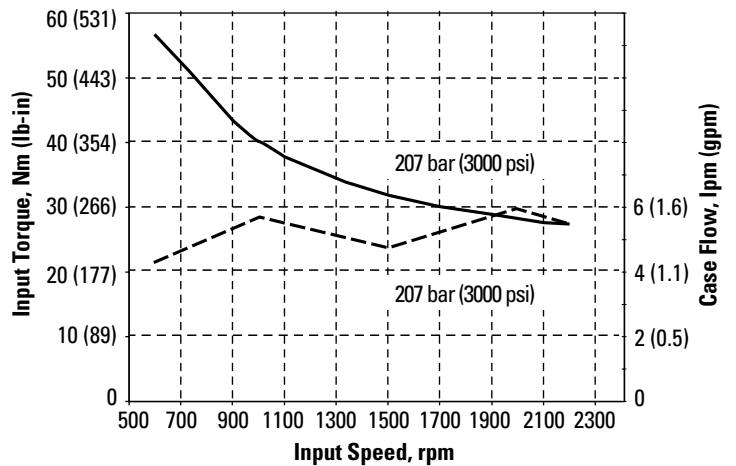

# Pump Installation

B-mount / Rear-ported

**RH Rotation**

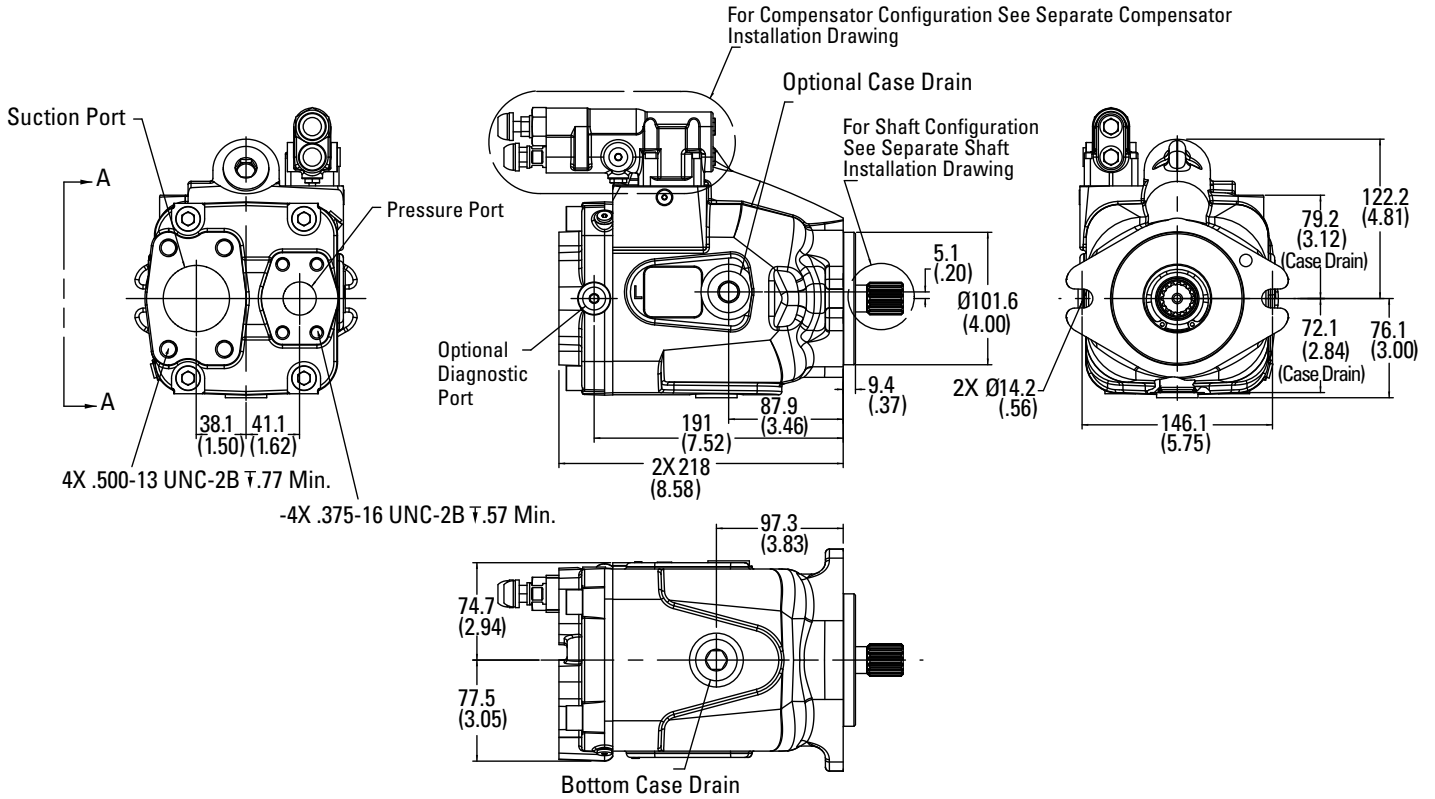
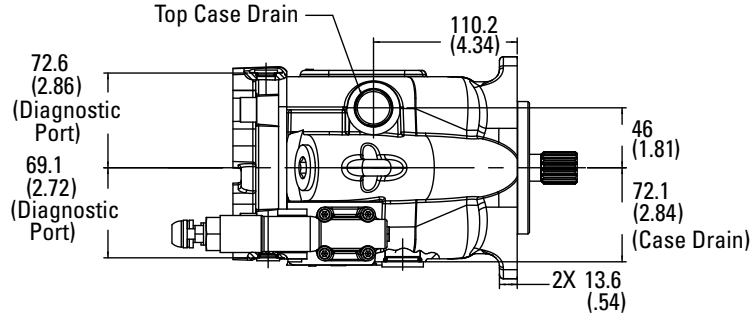

**View A - A**

**LH Rotation**

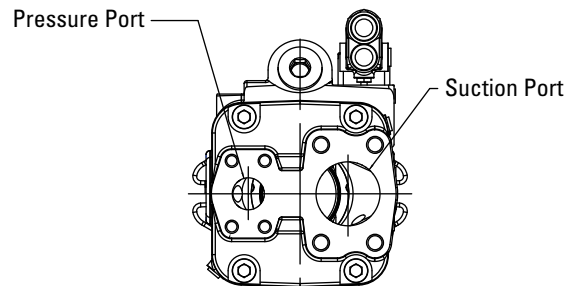
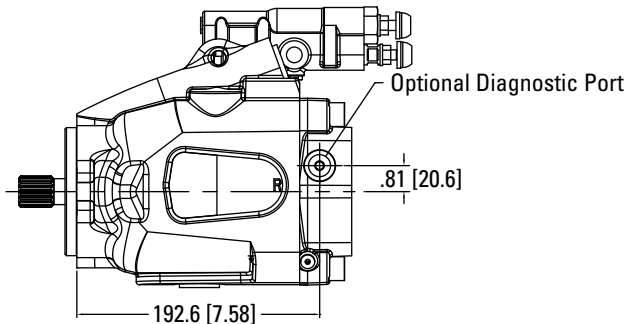

# Pump Installation

B-mount / Side-ported

## RH Rotation

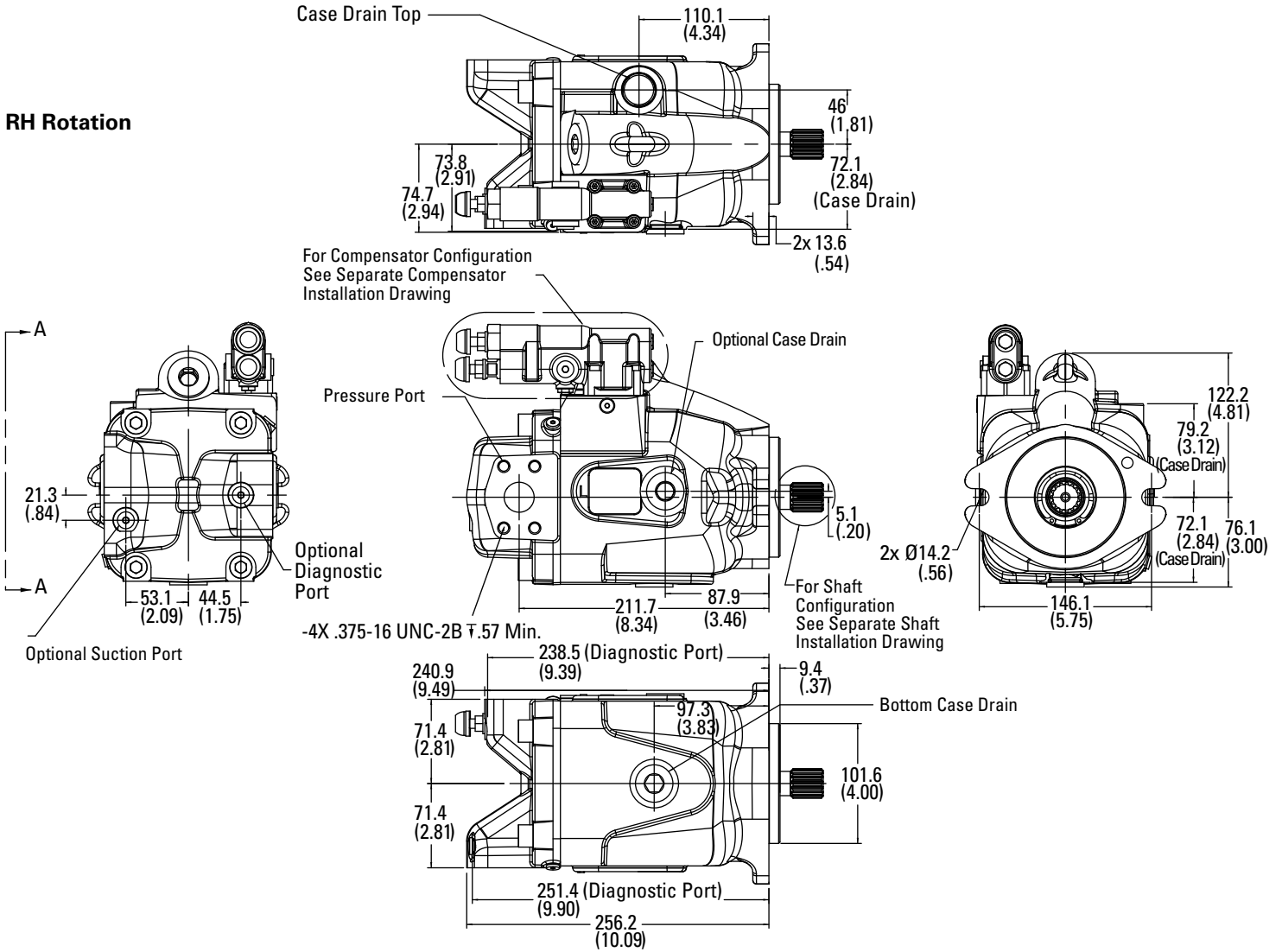

## View A - A

## LH Rotation

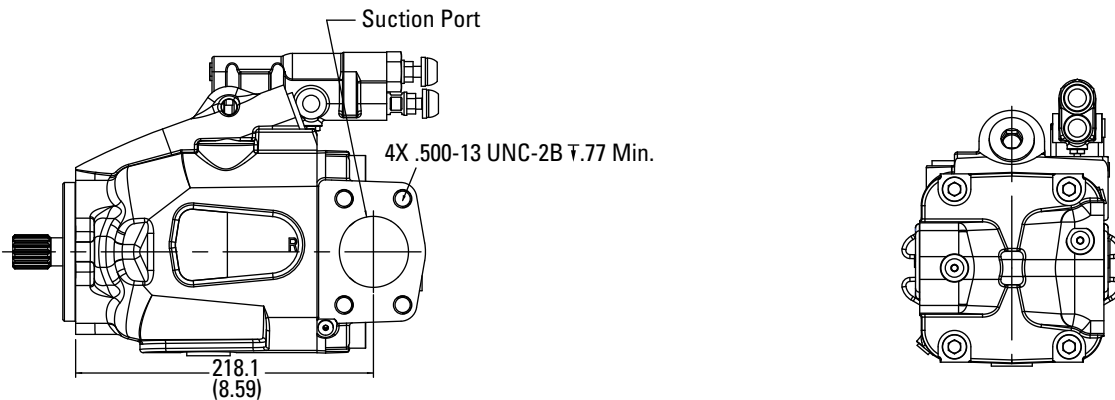



# Pump Installation

C-mount / Rear-ported

**RH Rotation**

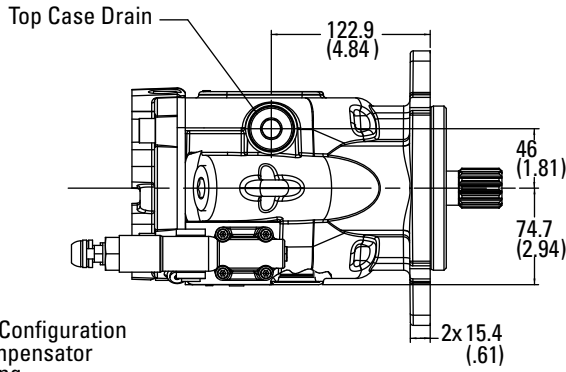

For Compensator Configuration  
See Separate Compensator  
Installation Drawing

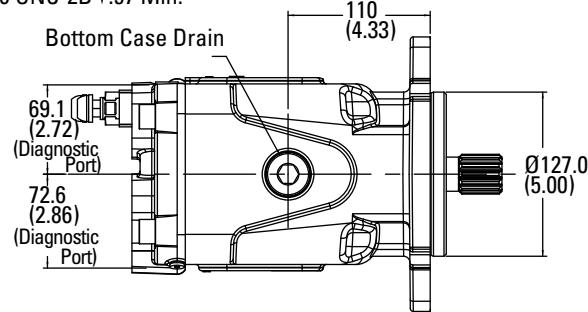
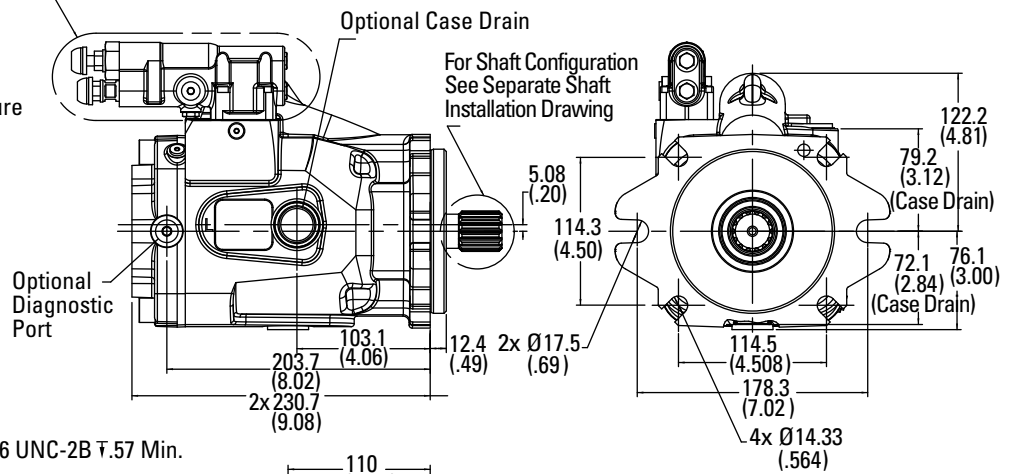
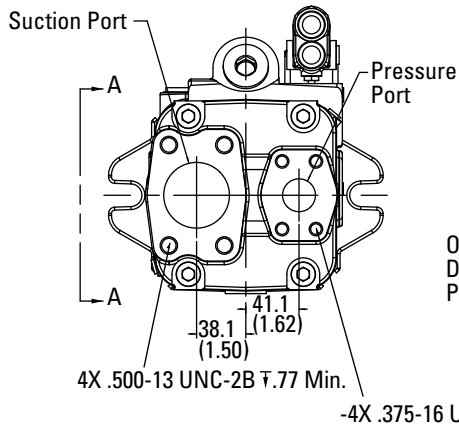

**View A - A**

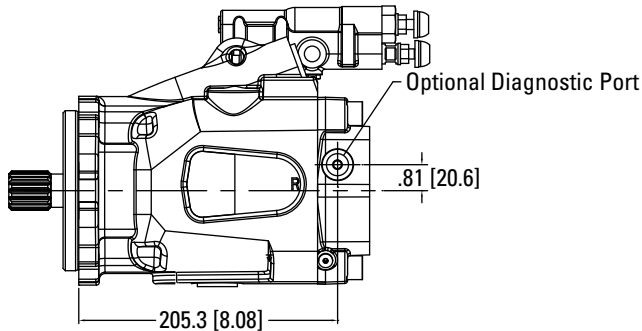

**LH Rotation**

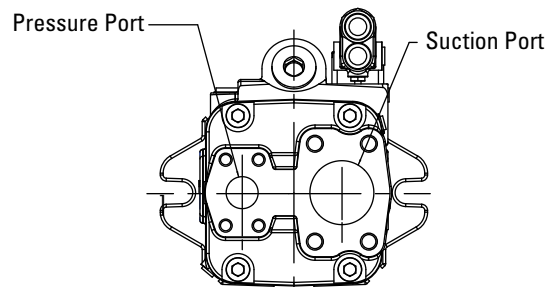

# Pump Installation

C-mount / Side-ported

**RH Rotation**

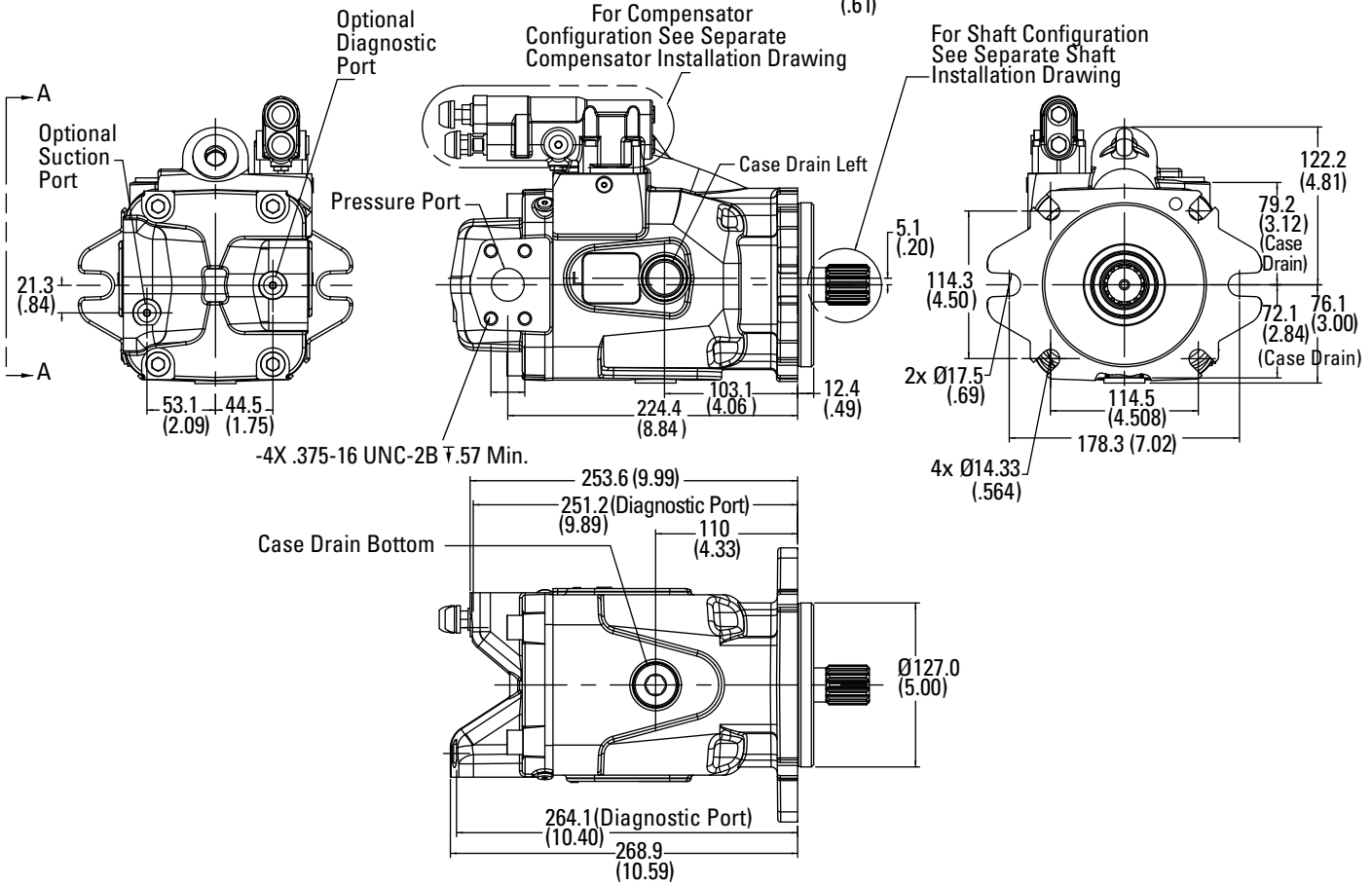
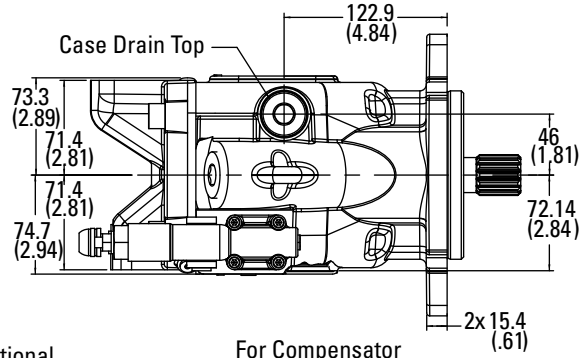

**View A - A**

**LH Rotation**

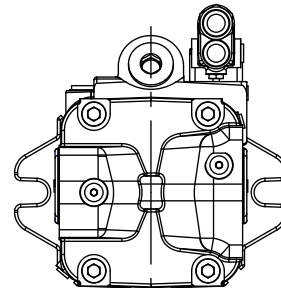
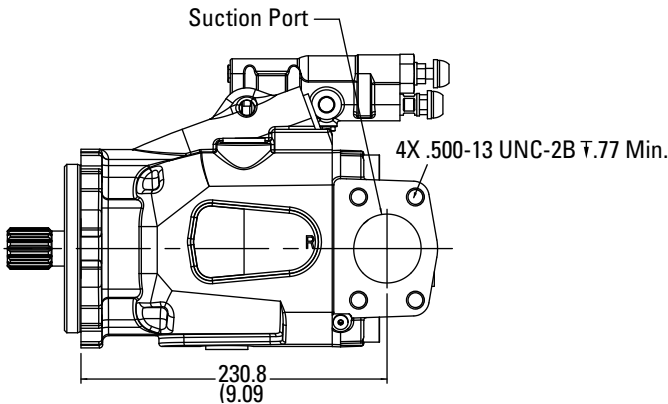

# Pump Installation

Thru-Drive SAE A

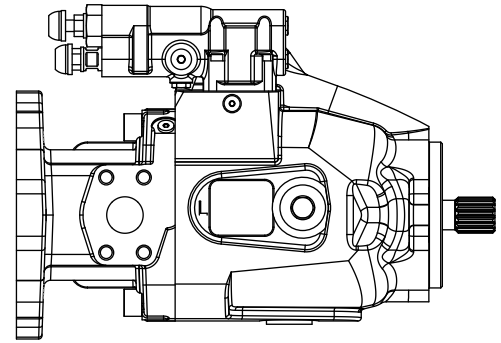
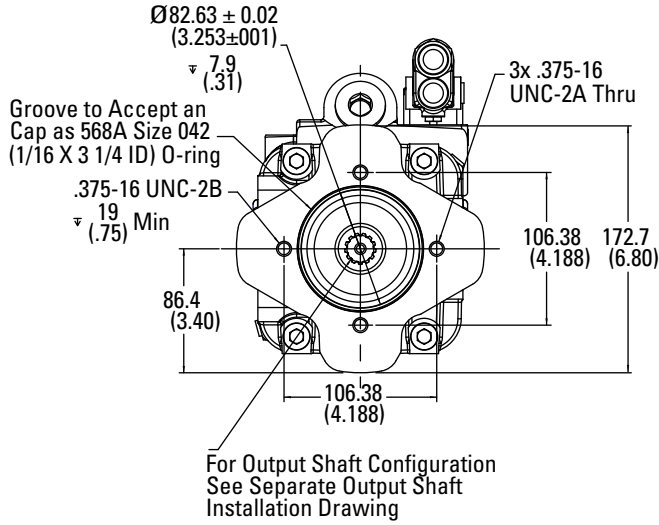

## A Thru-Drive Cover Plate Installation

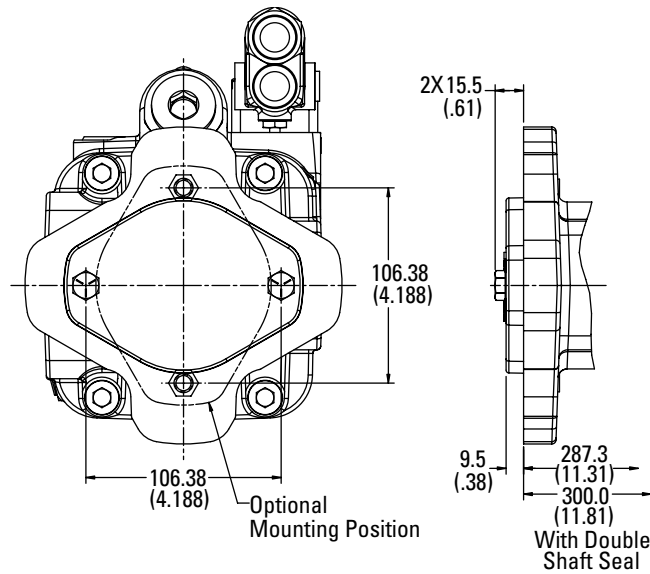

## Output Shaft Installation 9T Spline

### Maximum Torque

75 Nm (660 in-lbf)

$\varnothing 16.54$  (.651) 9 Tooth 30° Flat Root Side Fit 16/32 Class 5 Internal Spine per ANSI B92.1  
 Accepts 9 Tooth 30° Flat Root Side Fit 16/32 External Splines per SAE J498b Class 1 or ANSI B92.1 Class 5 with 31.8 (1.25) Extension From Mounting Flange  
 Additional Units Drive by This Spline Must Not Require More Than 74.6 N-m (55 Lbf-ft) of Torque

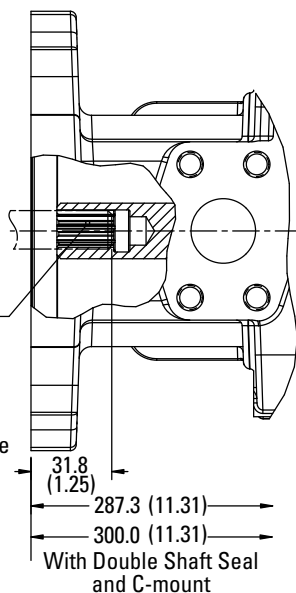

## Output Shaft Installation 11T Spline

### Maximum Torque

119 Nm (1056 in-lbf)

$\varnothing 19.33$  (.761) 11 Tooth 30° Flat Root Side Fit 16/32 Class 1 Internal Spine per SAE J498B  
 Accepts 11 Tooth 30° Flat Root Side Fit 16/32 External Splines per SAE J498B Class 1 or ANSI B92.1 Class 5 with 31.8 (1.25) Extension From Mounting Flange  
 Additional Units Driven by This Spline Must Not Require More Than 118.6 N-m (88 Lbf-ft) of Torque

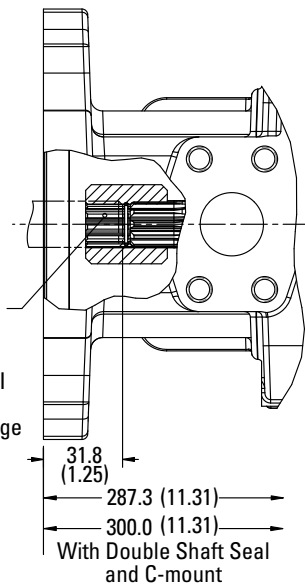

# Pump Installation

Thru-Drive SAE B

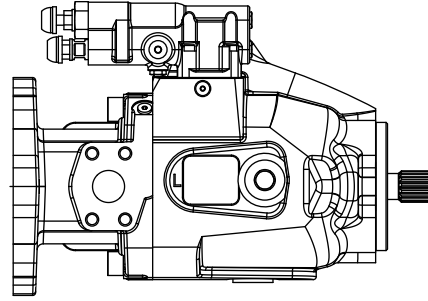
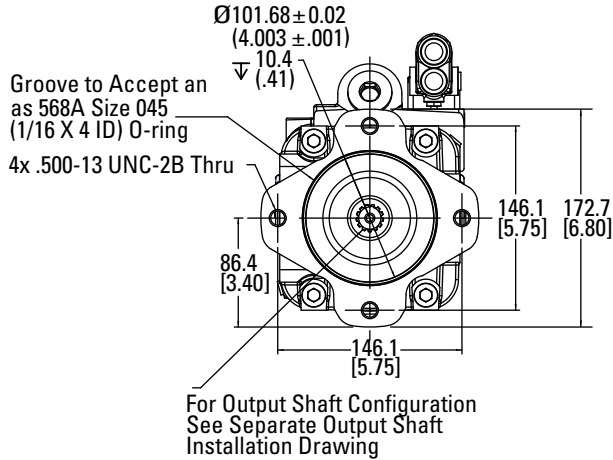

## B Thru-Drive Cover Plate Installation\*

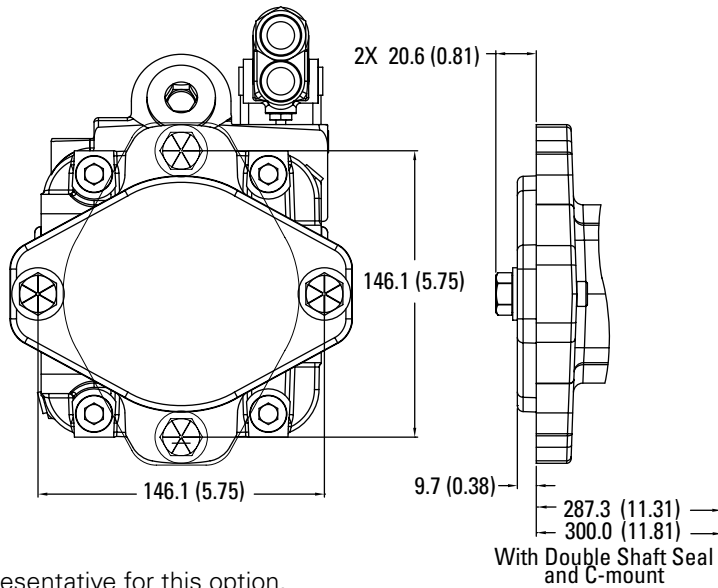

\* Contact your Eaton Representative for this option.

## Output Shaft Installation 13T Spline

**Maximum Torque**  
209 Nm (1850 in-lbf)

$\text{Ø}22.5$  (.886) 13 Tooth 30° Flat  
 Root Side Fit 16/32 Class 1  
 Internal Spline Per SAE J498B  
 Accepts 13 Tooth 30° Flat Root  
 Side Fit 16/32 External Splines  
 Per SAE J498B Class 1 or ANSI  
 B92.1 Class 5 with 41.2 (1.62)  
 Extension From Mounting Flange

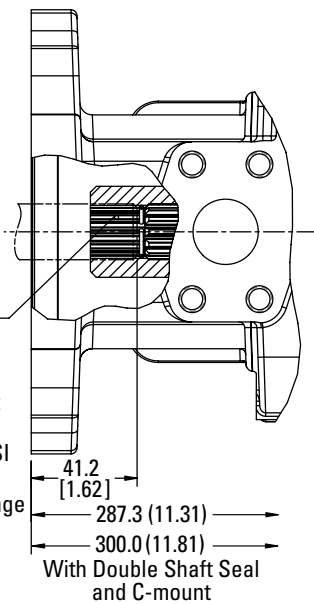

## Output Shaft Installation 15T Spline

**Maximum Torque**  
337 Nm (2987 in-lbf)

$\text{Ø}25.5$  (1.006) 15 Tooth 30° Flat  
 Root Side Fit 16/32 Internal  
 Spline per ASA B5.15-1960  
 Accepts 15 Tooth 30° Flat Root  
 Side Fit 16/32 External Splines  
 per SAE J498B Class 1 or ANSI  
 B92.1 Class 5 with 46 (1.81)  
 Extension From Mounting Flange

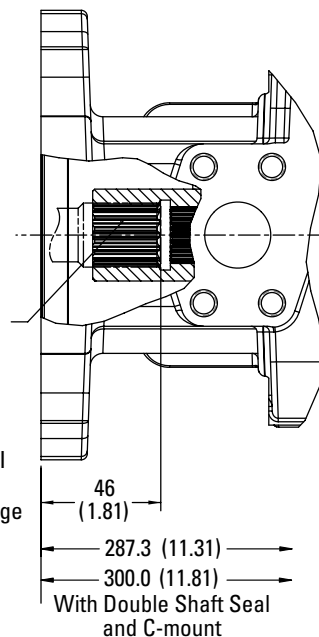

# Pump Installation

## Dual Shaft Seal

### B-Mount Dual Shaft Seal\*

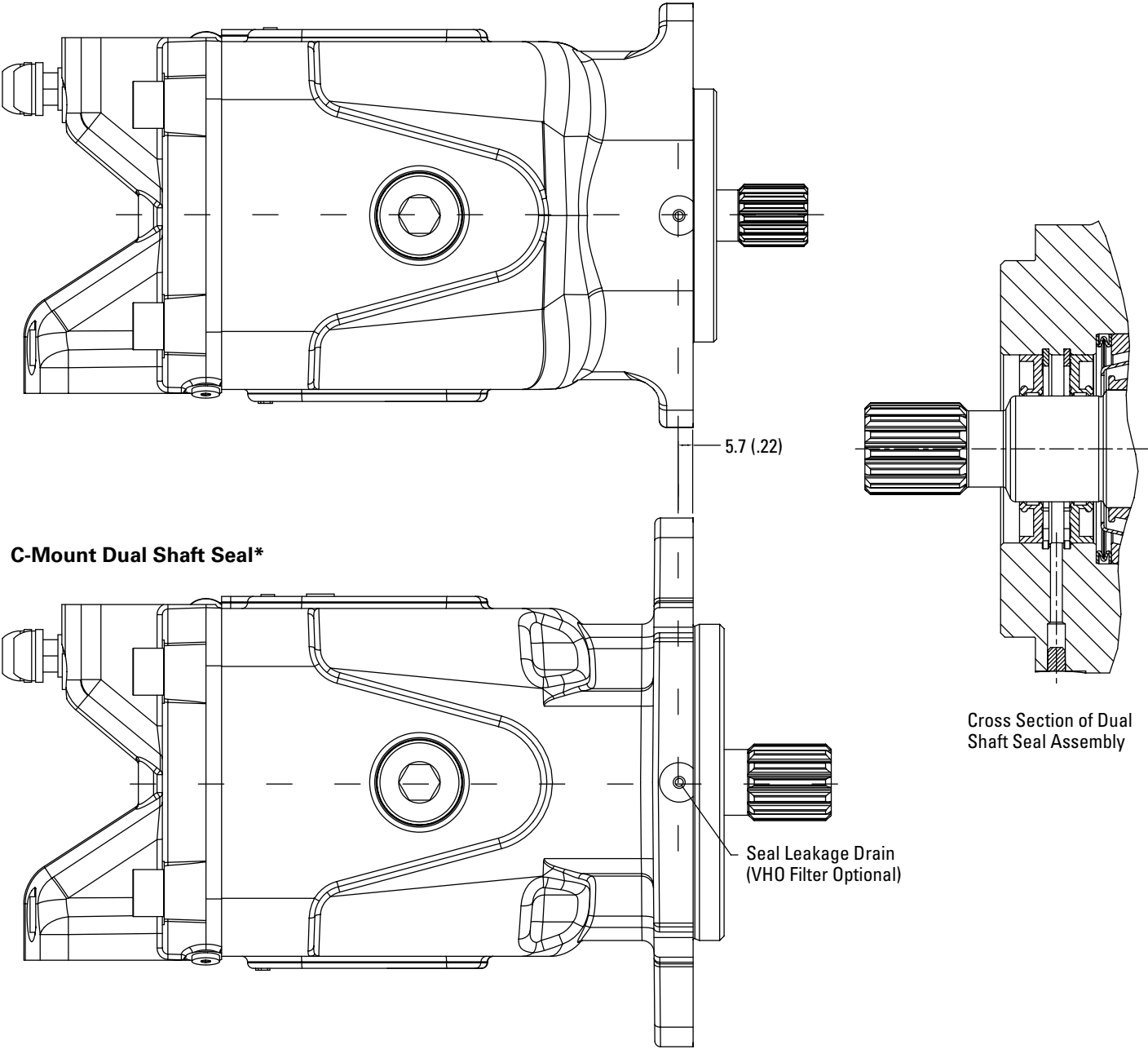

\* Refer to C-Mount Pump installation drawings for port locations.

# Control Installation

## Load Sense and Pressure Compensator

### Load Sense and Pressure Compensator

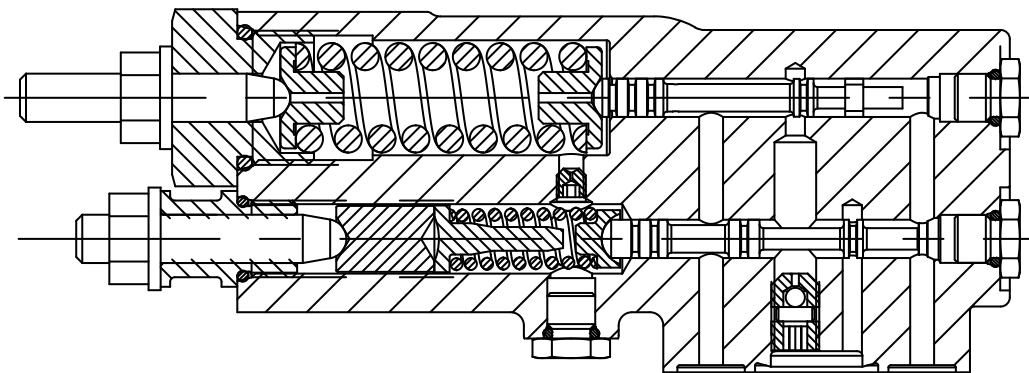
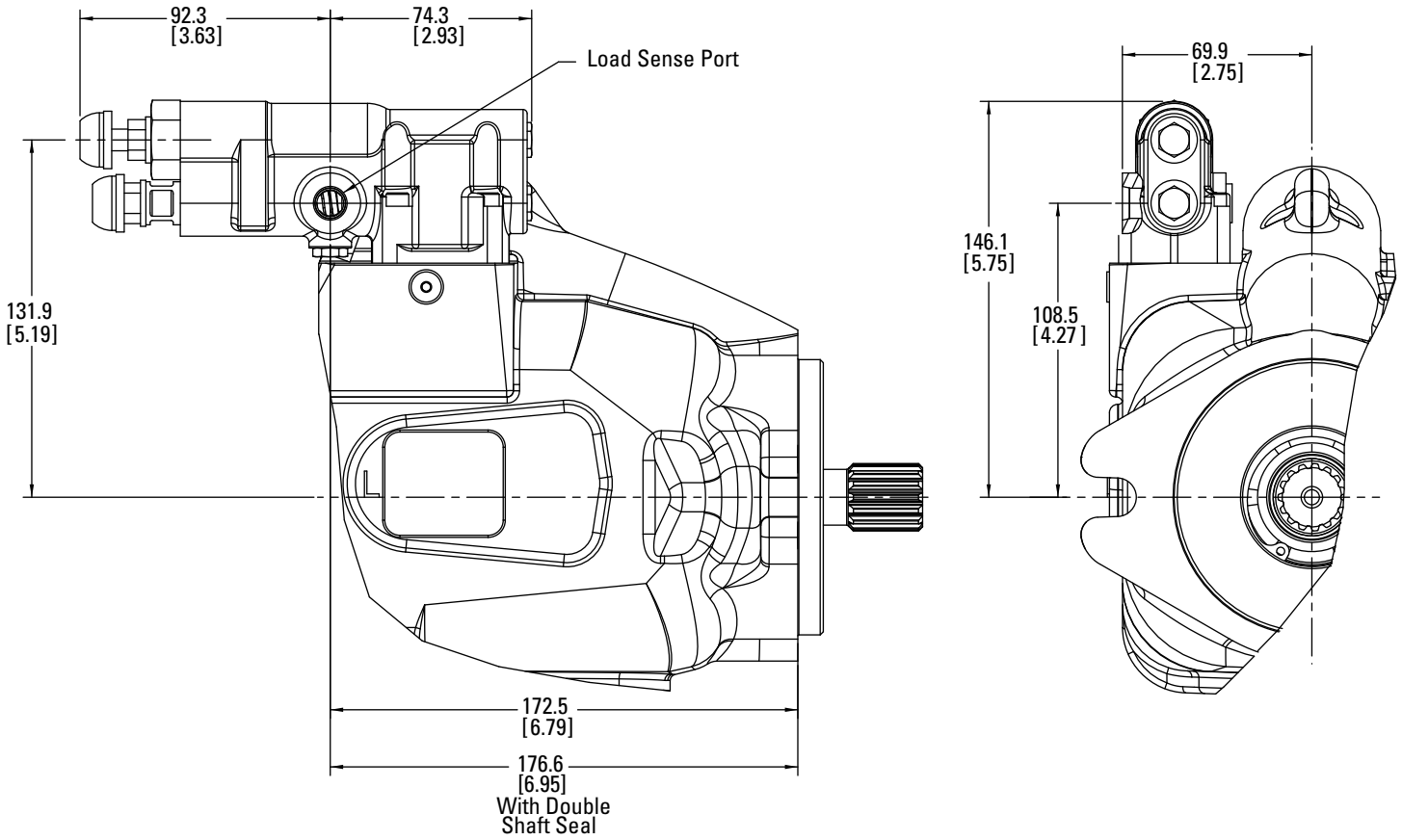

# Control Installation

## Pressure Compensator

### Pressure Compensator

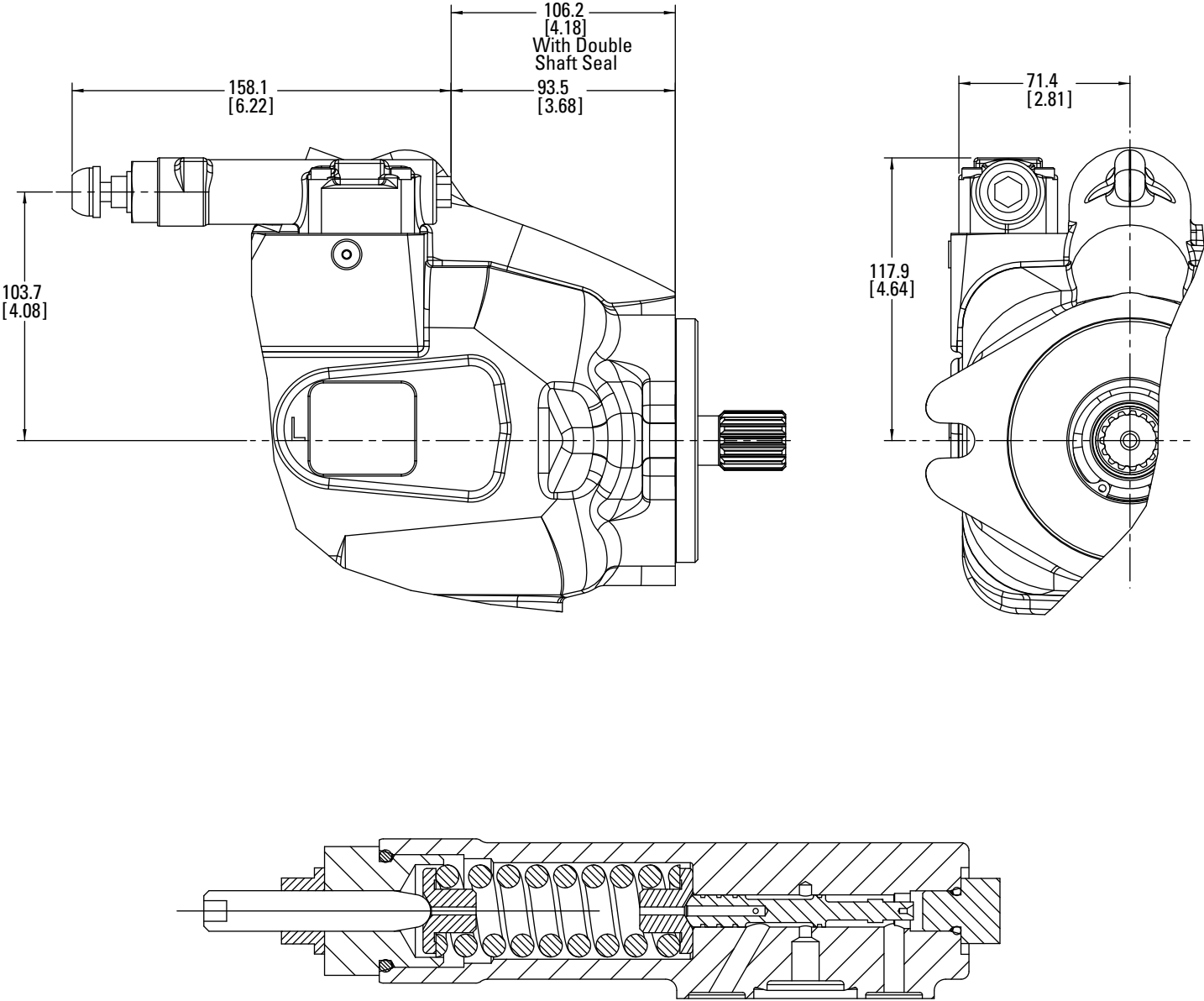

# Control Installation

Torque Control

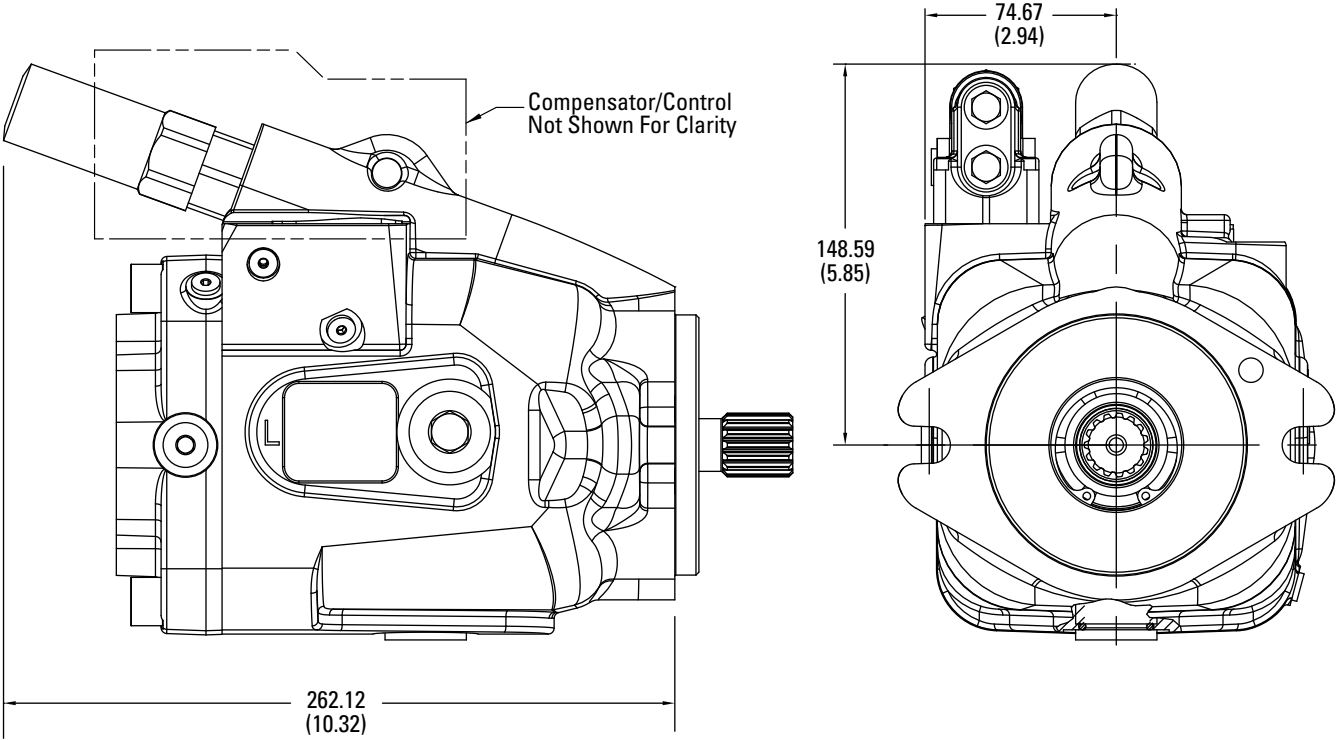



# Control Installation

Cold Start Valve

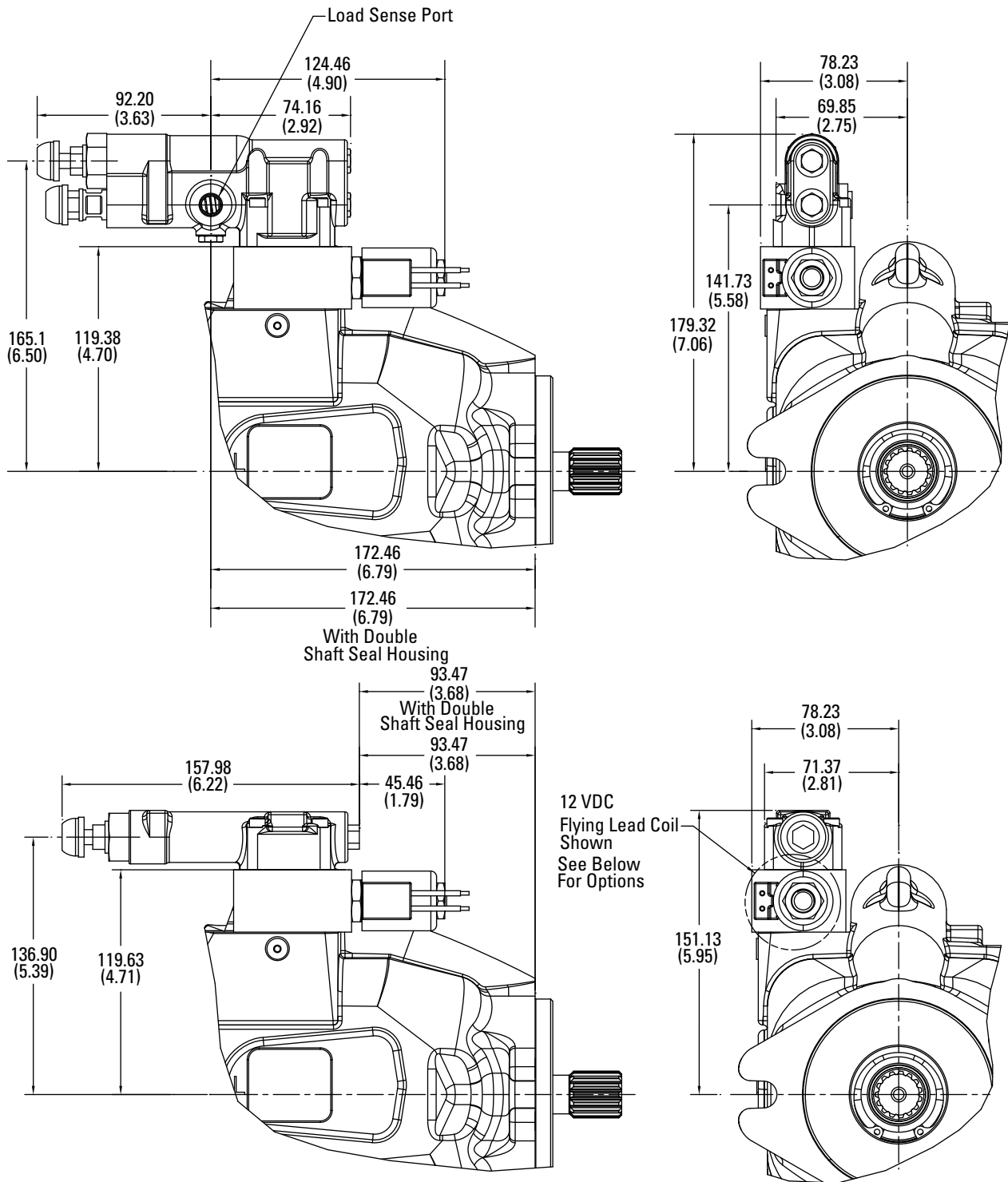

## Optional Connectors

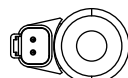

Deutsch Option

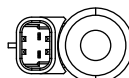

Metri-pack 280 Option



Metri-pack 150 Option

# External Manual Stroke Adjustment

## Maximum Stroke Limiter

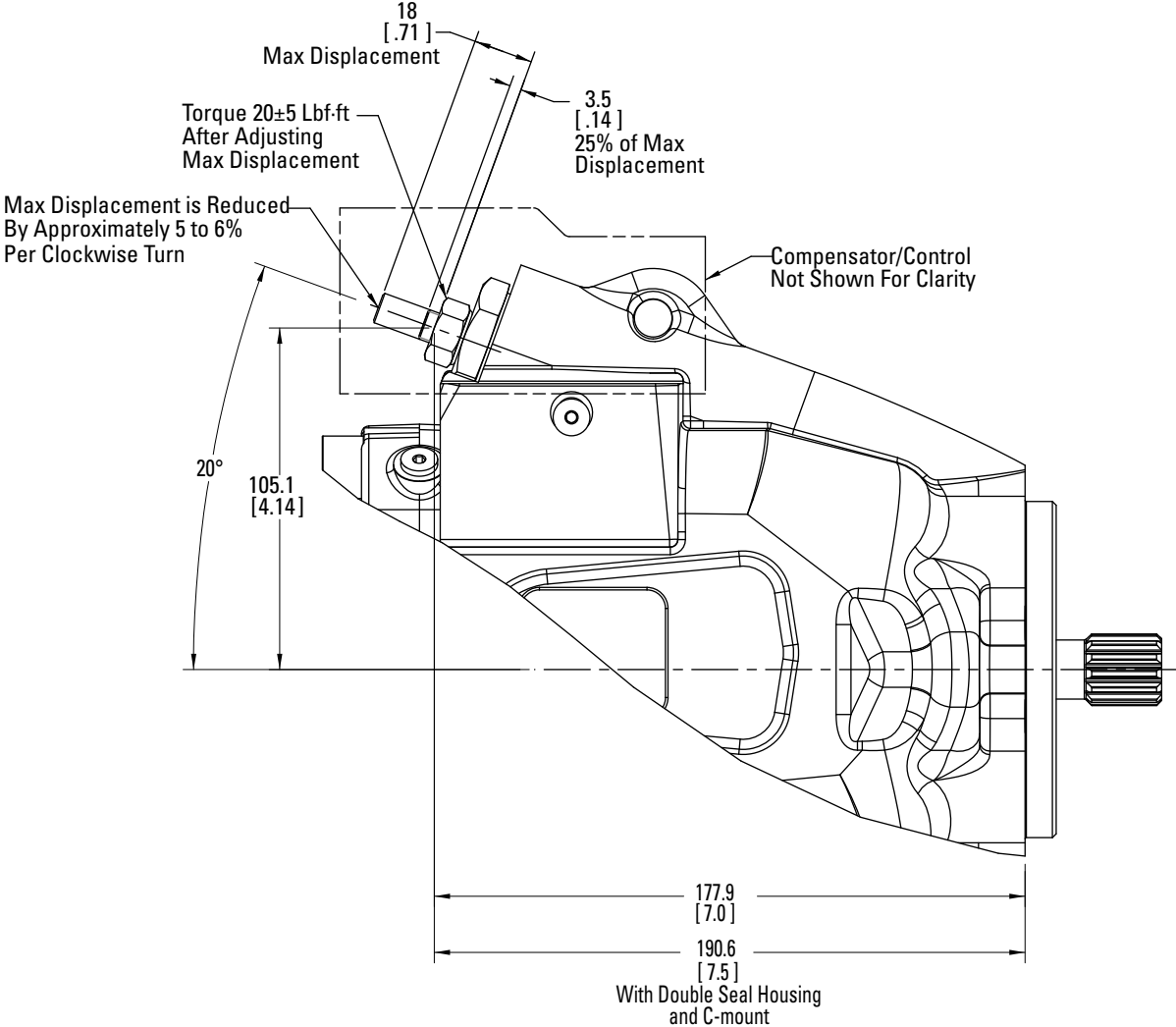

# Input Shaft Options

## 01 Code

### Maximum Torque

209 Nm  
(1850 in-lbf)

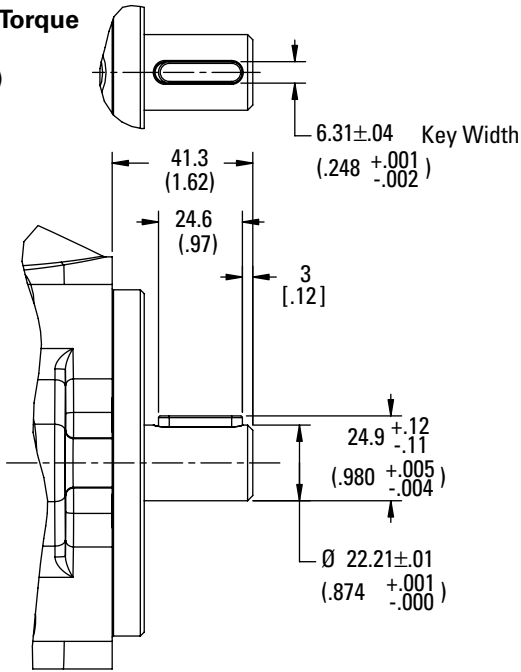

## 02 Code

### Maximum Torque

337 Nm  
(2987 in-lbf)

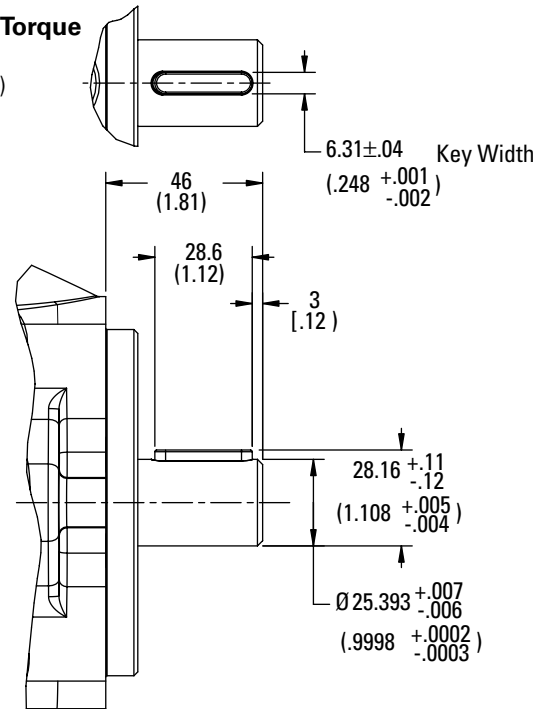

## 03 Code

### Maximum Torque

209 Nm  
(1850 in-lbf)

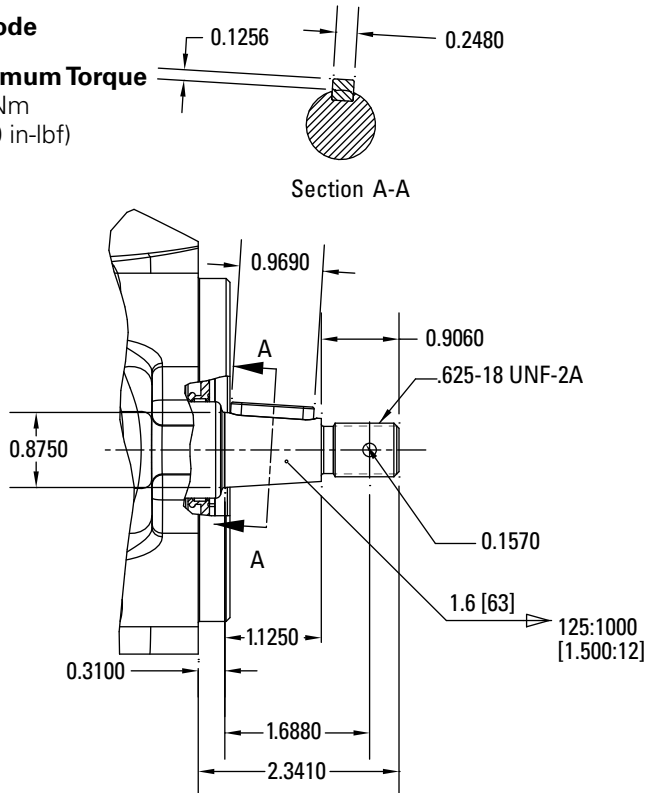

## 05 Code

### Maximum Torque

307 Nm  
(2717 in-lbf)

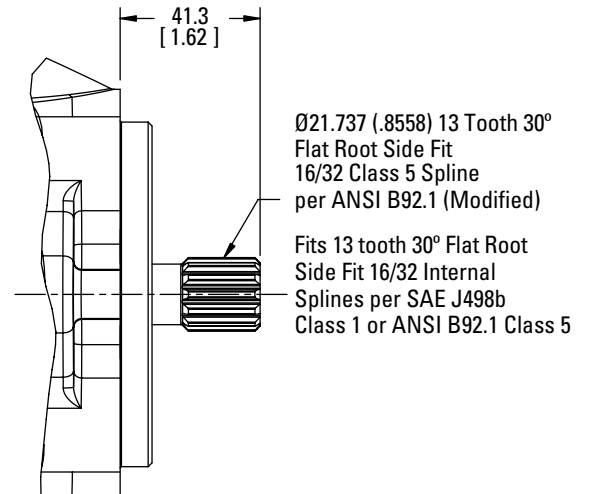

# Input Shaft Options

## 08 Code

### Maximum Torque

397 Nm  
(3514 in-lbf)

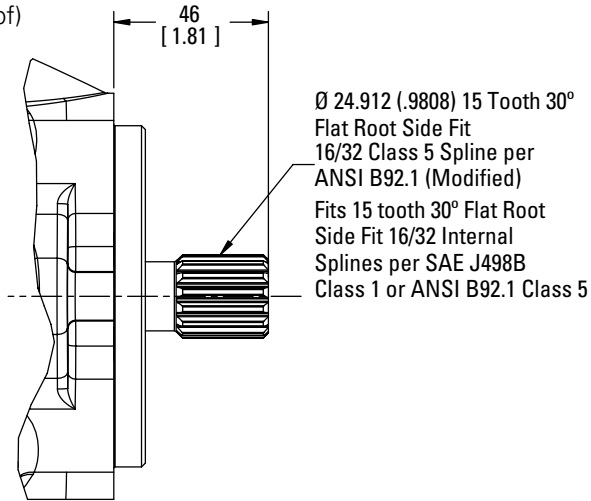

## 32 Code

### Maximum Torque

640 Nm  
(5660 in-lbf)

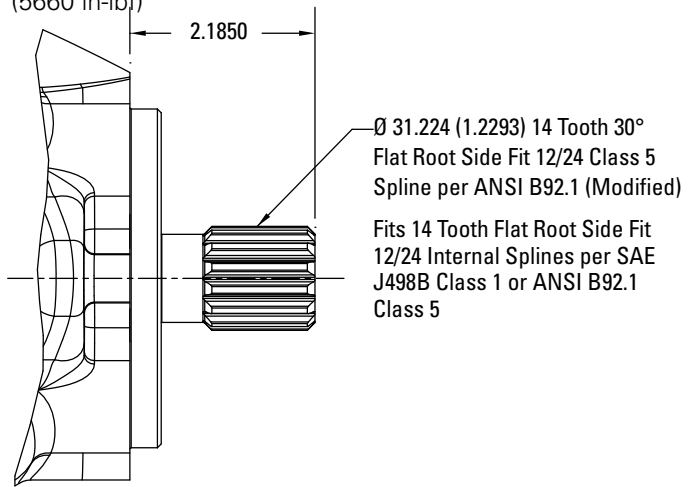

## 33 Code

### Maximum Torque

450 Nm  
(3980 in-lbf)

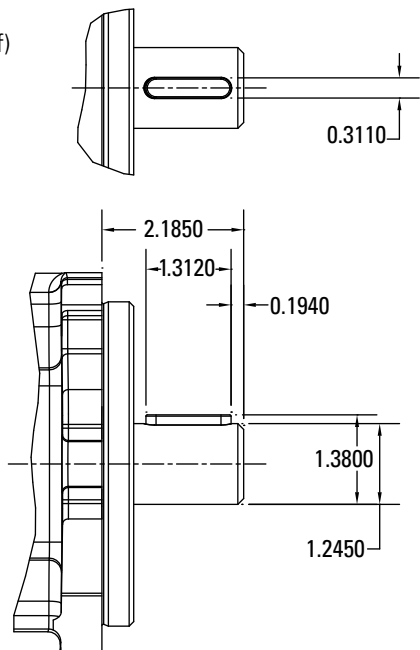

## 34 Code

### Maximum Torque

397 Nm  
(3514 in-lbf)

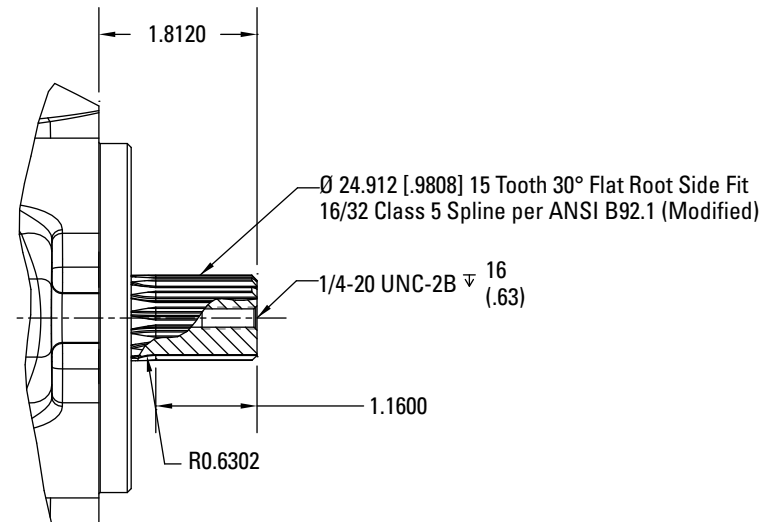

# Input Shaft Options

## 35 Code

### Maximum Torque

640 Nm  
(5660 in-lbf)

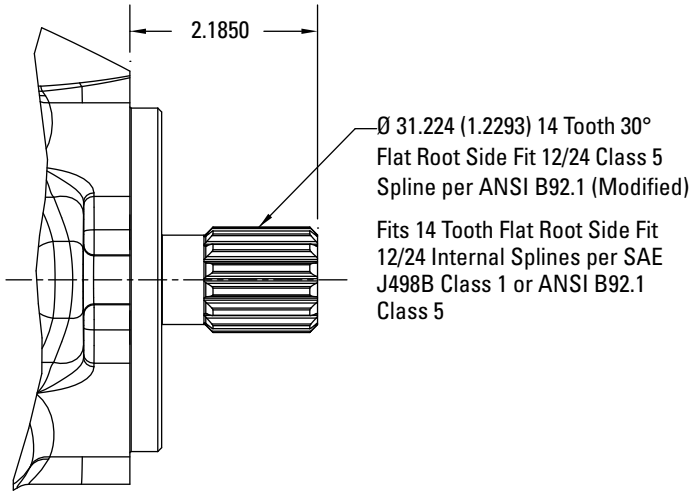

## 38 Code

### Maximum Torque

450 Nm  
(3980 in-lbf)

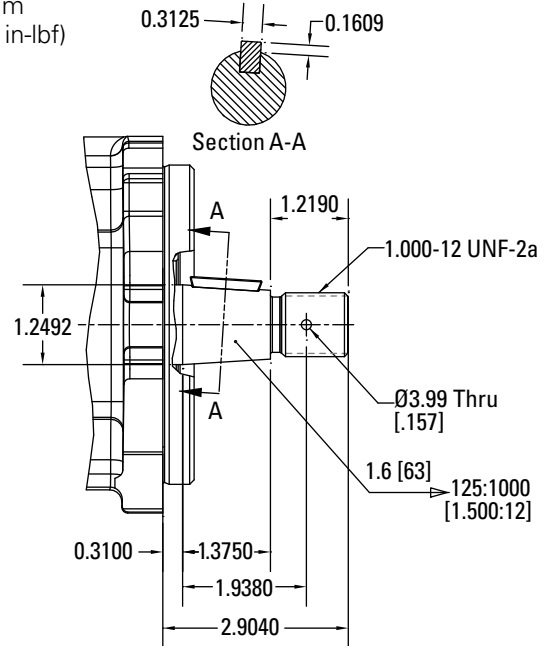

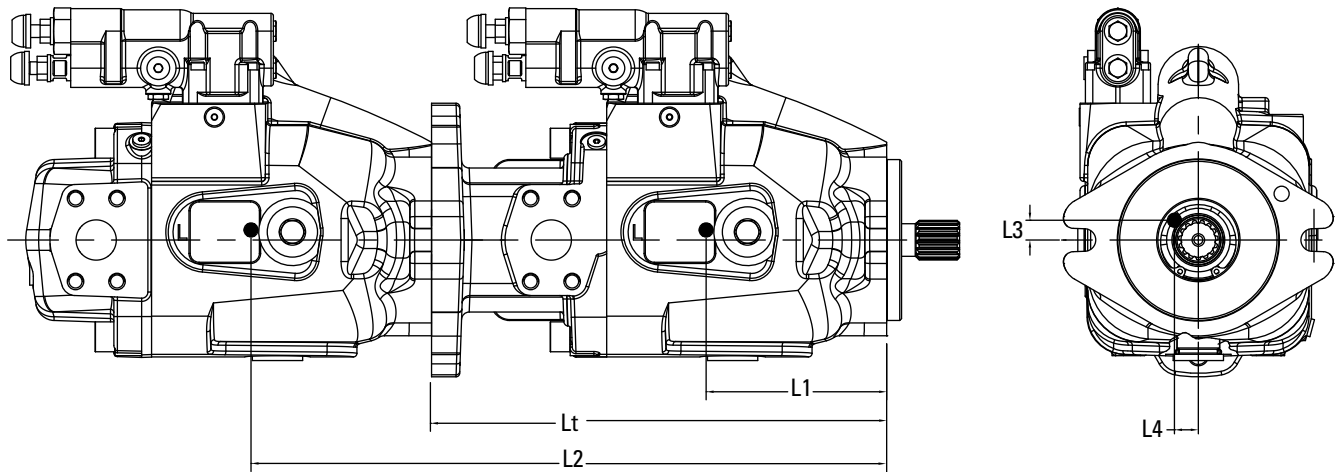

	Rear Port			Side Port			Thru-Drive			Length	Dual Seal
	Lcg	L3	L4	Lcg	L3	L4	Lcg	L3	L4	Lt	Lds
ADU041	109.6 (4.31)	9.6 (0.38)	2.9 (0.11)	114.7 (4.51)	9.2 (0.36)	2.4 (0.10)	131.5 (5.18)	8.2 (0.32)	2.1 (0.08)	287.3 (11.31)	13.0 (0.50)
ADU049	109.6 (4.31)	9.6 (0.38)	2.9 (0.11)	114.7 (4.51)	9.2 (0.36)	2.4 (0.10)	131.5 (5.18)	8.2 (0.32)	2.1 (0.08)	287.3 (11.31)	13.0 (0.50)
ADU062	109.9 (4.32)	9.4 (0.37)	2.9 (0.11)	114.9 (4.52)	9.0 (0.35)	2.4 (0.10)	131.3 (5.17)	8.0 (0.31)	2.1 (0.08)	287.3 (11.31)	13.0 (0.50)
ADU080	109.9 (4.32)	9.4 (0.37)	2.9 (0.11)	114.9 (4.52)	9.0 (0.35)	2.4 (0.10)	131.3 (5.17)	8.0 (0.31)	2.1 (0.08)	287.3 (11.31)	13.0 (0.50)

Dimensions in mm (in)

## Examples: Calculation L<sub>1</sub> and L<sub>2</sub>

### Tandem ADU062 Thru-drive with ADU041 Rear Ported

$$L_1 = L_{cg} \quad 131.3\text{mm (5.17 inches)}$$

$$L_2 = L_t + L_{cg} \quad 287.3\text{mm} + 109.6\text{mm} = 396.9\text{mm (15.6 inches)}$$

### Tandem Dual Seal ADU049 Thru-drive with ADU049 Side Ported

$$L_1 = L_{cg} + L_{ds} \quad 131.5\text{mm} + 13\text{mm} = 144.5\text{mm (5.69 inches)}$$

$$L_2 = L_t + L_{ds} + L_{cg} \quad 287.3\text{mm} + 13\text{mm} + 114.7\text{mm} = 415\text{mm (16.34 inches)}$$

## Tandem Pump Applications

Eaton recommends that tandem pump applications be provided with additional support to limit overhung loading of the mounting flange. The thru-drive alternate attachment points on the rear flange may be used with a customer designed support.

# Installation and Start-up

**Warning:** Care should be taken that mechanical and hydraulic resonances are avoided in the application of the pump. Such resonances can seriously compromise the life and/or safe operation of the pump.

## Drive Data

Mounting attitude should be horizontal using the appropriate case drain ports to ensure that the case remains full of fluid at all times. Consult your local Eaton Representative if a different arrangement is required.

## Fluid Cleanliness

The 420 Series pumps are rated in anti-wear petroleum fluids with a contamination level of 21/18/13 per ISO 4066. Operation in fluids with levels more contaminated than this is not recommended. Fluids other than petroleum, severe service cycles, or temperature extremes are cause for adjustment of these codes. Please contact your Eaton Representative for specific duty cycle recommendation.

In those cases where geometric tolerances of mounting are critical, or where specific tolerance ranges are required and not specified, consult Eaton Engineering for specific limits.

Direction of shaft rotation, viewed from the prime mover end, must be as indicated in the model designation on the pump – either right hand (clockwise) or left hand (counterclockwise).

Direct coaxial drive through a flexible coupling is recommended. If drives imposing radial shaft loads are considered, please consult your Eaton Representative.

Eaton 420 Series pumps, as with any variable displacement piston pumps, will operate with apparent satisfaction in fluids up to the rating specified here. Experience has shown however, that pump and hydraulic system life is not optimized with high fluid contamination levels (high ISO cleanliness codes).

Proper fluid condition is essential for long and satisfactory life of hydraulic

## Start-up Procedure

Make sure the reservoir and circuit are clean and free of dirt/debris prior to filling with hydraulic fluid.

Fill the reservoir with filtered oil and fill to a level sufficient enough to prevent vortexing at the suction connection to pump inlet. It is good practice to clean the system by flushing and filtering, using an external slave pump.

**Caution:** Before the pump is started, fill the case through the uppermost drain port with hydraulic fluid of the type to be used. The case drain line must be connected directly to the reservoir and must terminate below the oil level.

components and systems. Hydraulic fluid must have the correct balance of cleanliness, materials, and additives for protection against wear of components, elevated viscosity and inclusion of air.

Essential information on the correct methods for treating hydraulic fluid is included in Eaton publication 561 – “Eaton Guide to Systemic Contamination Control”

Once the pump is started, it should prime within a few seconds. If the pump does not prime, check to make sure that there are no restrictions between the reservoir and the inlet to the pump, and that the pump is being rotated in the proper direction, and that there are no air leaks in the inlet line and connections. Also check to make sure that trapped air can escape at the pump outlet.

After the pump is primed, tighten the loose outlet connections, then operate for five to ten minutes (unloaded) to remove all trapped air from the circuit.

If the reservoir has a sight gage, make sure the fluid is clear – not milky.

– available from your local Eaton distributor. In this publication, filtration and cleanliness levels for extending the life of axial piston pumps and other system components are listed. Included is an excellent discussion of the selection of products needed to control fluid condition.

Eaton  
Hydraulics Group USA  
14615 Lone Oak Road  
Eden Prairie, MN 55344  
USA  
Tel: 952-937-9800  
Fax: 952-294-7722  
[www.eaton.com/hydraulics](http://www.eaton.com/hydraulics)

Eaton  
Hydraulics Group Europe  
Route de la Longeraie 7  
1110 Morges  
Switzerland  
Tel: +41 (0) 21 811 4600  
Fax: +41 (0) 21 811 4601

Eaton  
Hydraulics Group Asia Pacific  
Eaton Building  
4th Floor, No.3 Lane280 Linhong Rd.  
Changning District  
Shanghai 200335  
China  
Tel: (+86 21) 5200 0099  
Fax: (+86 21) 5200 0400